

We support the
innovations of customers

Leak - Proof Flow & Control Solution Partner

The Best Partner
for Value Creation

S-LOK Rising Plug Valves

Rising Plug Valves



SRPV60

Product Information

Features

- Bi-directional flow control.
- Replaceable seat design: Acetal seat standard, optional PEEK and PFA are available.
- Non-rotating Stem Tip are composed for positive sealing and maximize soft seat life.
- Internal bonnet O-ring protects threads from external contamination.
- Isolated threads' location above the sealing rings prevent media contamination and thread lubricant washout.

Materials of Construction

Ratings are based on standard stem tip of FKM O-ring and PTFE backup rings.

Component	Grade/ASTM Specification	
1	Handle, Set screw	S316 / A276
2	Bonnet O-ring	FKM O-ring
3	Stem Shank	S316 / A276 or A479
4	Stem Tip	
5	Seat	Acetal / D4181, Optional : PEEK, PFA
6	Stem tip O-ring	FKM O-ring
7	Backup Rings (2)	PTFE / D1710
8	Bonnet	S316 / A276 or A479
9	Locking Nut	
10	Body	S316 / A276 or A479

Wetted components are listed in Red.

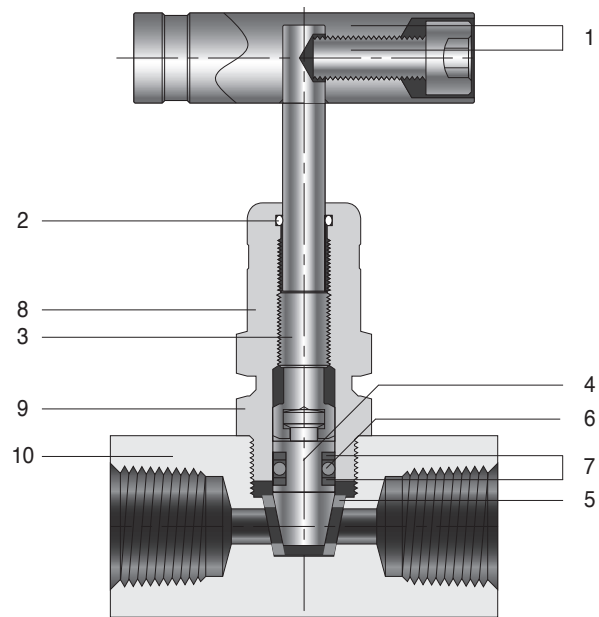

Pressure-Temperature Ratings

Ratings are based on standard stem tip of FKM O-ring and PTFE backup rings.

Body Material	S316		
	Acetal	PEEK	PFA
Temperature °F(°C)	Working Pressure, psig(barg)		
-20 to 100 (-28 to 37)	6,000(413)	6,000(413)	750(51.6)
200 (93)	2,650(182)	3,000(206)	625(43.0)
250 (121)	1,000(68.9)	1,600(110)	450(31.0)
300 (148)	-	1,300(89.5)	300(20.6)
350 (176)	-	1,200(82.6)	200(13.7)
400 (204)	-	1,000(68.9)	100(6.8)

Valve with Actal seat : For water and steam application, standard valve with Acetal seat is not recommended for application of greater than 200°F (93°C) temperature.



Product Information

Ordering information and Dimensions

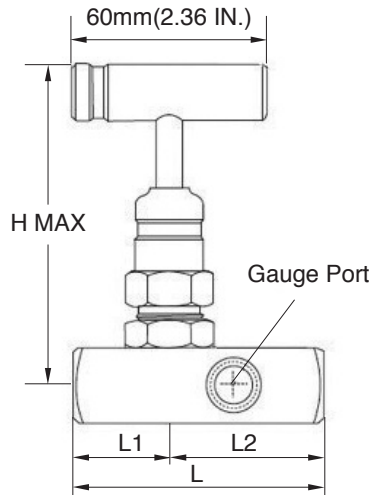

Basic Ordering Number		End Connections		Orifice Mm (in.)	Cv	Dimensions, mm(in.)			
		Inlet	Outlet			L	L1	L2	H
SRPV1-	F-4N	1/4 F NPT		4.8 (0.187)	0.63	56.9 (2.24)	28.4 (1.12)	28.4 (1.12)	95.8 (3.77)
	MF-4N	1/4 M NPT	1/4 F NPT			73.4 (2.90)	45.2 (1.78)		
	MF-8N4N	1/2 M NPT	1/4 F NPT			76.5 (3.01)	48.0 (1.89)		
SRPV1-G4-	F-4N	1/4 F NPT				72.9 (2.87)	28.4 (1.12)	44.4 (1.75)	
	MF-8N4N	1/2 M NPT	1/4 F NPT			124 (4.87)	79.2 (3.12)		
SRPV2-	F-8N	1/2 F NPT				6.2 (0.24)	1.8	67.6 (2.66)	
	MF-8N	1/2 M NPT	1/2 F NPT	88.6 (3.49)	54.9 (2.16)				
	MF-12N8N	3/4 M NPT	1/2 F NPT	90.9 (3.58)	33.8 (1.33)				
SRPV2-G8-	F-8N	1/2 F NPT		90.9 (3.58)	33.8 (1.33)			57.2 (2.25)	
	MF-8N	1/2 M NPT	1/2 F NPT	142 (5.58)	84.6 (3.33)				
	MF-12N8N	3/4 M NPT	1/2 F NPT						

- All dimensions shown are for reference only and are subjected to change.
- SRPV1-G4 gauge port: 1/4 in. Female NPT, SRPV2-G8: 1/2 in. Female NPT.
- Gage port valves with pipe installation extended body of 2.0 in. (50 mm) are Red.