

SBV30 Series For working pressure up to 3000 psig(206bar)

1. Handle with Arrow

- indicates flow direction.
- allows quick operation to open and close.

2. Panel Mounting Nut

- allow easy installation.

3. Variety of End Connections

- include fractional/metric S-LOK tube fittings, NPT female, ISO female threads.

4. One-piece body

- reduces the number of potential leak points.

5. Orifice

- is optimized design for minimum pressure drop.

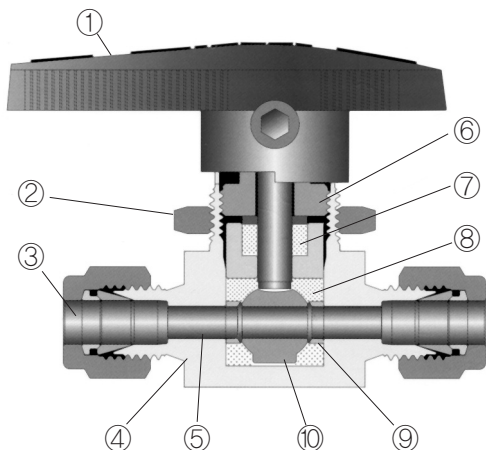

6. Packing Bolt

- allows easy packing adjustment with valve in-line.

7. PTFE Packing

- is supported by top and bottom glands.

8. Encapsulating Ball Seats

- virtually allow no dead volume.
- are uniformly forced to form tight seals against ball and body cavity.

9. Support rings and discs

- retains the capsule packing and prevent cold flow.

10. Integral Ball-Stem

- is machined from one piece bar stock.
- is best suited to encapsulate ball seats.

Features

- Pressure rating up to 3000psig(206bar) @70°F(21°C).
- Temperature rating from 50°F(10°C) to 150°F(65°C) with standard PTFE seat and packing.
- Choice of materials : Standard S316 and available in alloy 400 and Brass.
- Vent to atmosphere available.
- Every valve is 100% factory tested with the Nitrogen @1000psi (69bar).

Technical Data

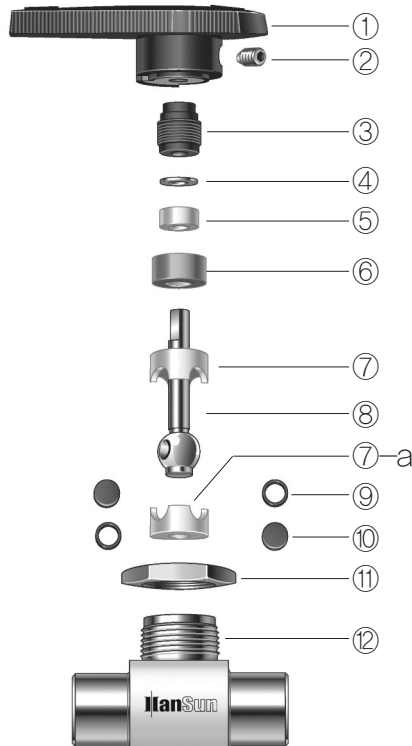

Materials of construction

Description	Grade / ASTM Specification	
	Valve Body Materials	
	S316	Brass
1 Handle	Black Nylon	
2 Set screw	17-4PH/A564	
3 Packing bolt	S316/A479, A276	Brass/B16
4 Upper grand	S316/A479, A276	
5 Packing	PTFE/D1710	
6 Lower grand	S316/A479, A276	Brass/B16
7 & 7-a Upper&Lower Ball seat	PTFE/D1710	
8 Ball stem	S316/A479, A276	
9 Support rings	S316	
10 Side discs	(Fluorocarbon-coated)	
11 Panel nut	S316	Brass/B16
12 Body	/A479, A276	

• Pressure Rating with standard PTFE seat

Valve Designator	Straight 2-way	Angle 2-way	Switching 3-way	Temperature Range
SBV 1	2500psig (172bar)			50°F to 150°F (10°C to 65°C)
SBV 2	3000psig (206bar)	2500psig (172bar)		
SBV 3	2500psig (172bar)	1500psig (103bar)		
SBV 4	2500psig (172bar)	1500psig (103bar)		

2-Way (Shut-Off Valve)

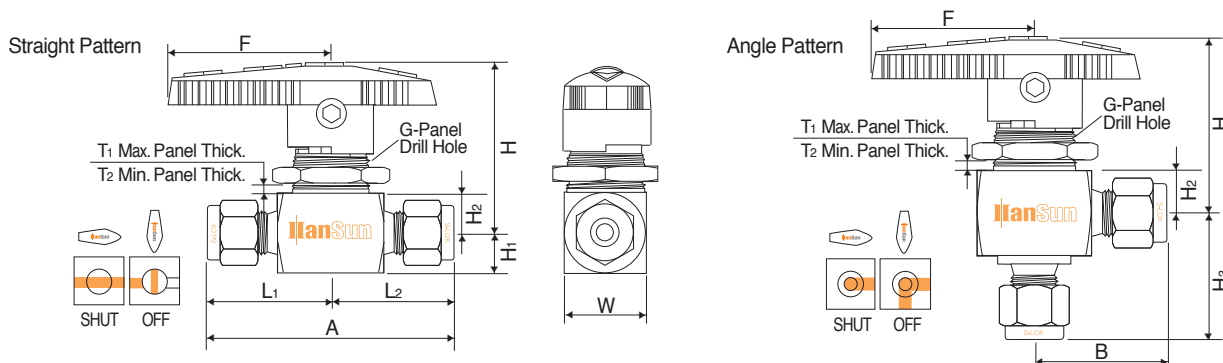

Ordering Information and Dimensions

Basic Ordering Number	Orifice		Cv		End Connections		Dimensions (mm)														
	mm	inch	Inline	Angle	Inlet	Outlet	A	L1	L2	H3	H2	H1	F	T1	T2	G	H	W			
SBV1	S-1T	1.3	0.052	0.1	-	1/16" S-LOK	42.7	21.3	-												
	S-2T	2.4	0.093	0.2	0.15	1/8" S-LOK	51.1	25.6	24.6												
	S-3M			0.2	0.15	3mm S-LOK	51.1	25.6	24.6	8.6	7.1	28.4	6.4	2.0	15.1	34.5	14.7				
	S-4T	3.2	0.125	0.6	0.35	1/4" S-LOK	56.1	28.1	27.2												
	S-6M			0.6	0.35	6mm S-LOK	56.1	28.1	27.2												
	F-2N			0.5	0.3	1/8" Female NPT	41.1	20.6	20.6												
SBV2	S-4T	4.8	0.187	2.4	0.9	1/4" S-LOK	59.9	30.0	29.7												
	S-6T			1.5	0.9	3/8" S-LOK	65.5	32.8	32.8												
	S-6M			2.4	0.9	6mm S-LOK	60.7	30.4	29.7												
	S-8M			1.5	0.9	8mm S-LOK	62.5	31.2	30.5	11.2	9.7	38.9	4.8	2.5	19.8	39.6	19.8				
	F-2N			1.2	0.7	1/8" Female NPT	50.8	25.4	25.4												
	F-4N			0.9	0.75	1/4" Female NPT	52.3	26.2	26.2												
	M-4N			1.2	0.75	1/4" Male NPT	50.8	25.4	26.2												
	F-4R			0.9	0.75	1/4" ISO Female Tapered	52.3	26.2	-												
SBV3	S-6T	7.1	0.281	6.0	2.0	3/8" S-LOK	77.5	38.8	36.3												
	S-10M			6.0	2.0	10mm S-LOK	78.0	38.9	36.9												
	F-4N			3.0	1.7	1/4" Female NPT	63.5	31.8	31.8	14.2	14.2	50.8	9.5	3.0	28.6	52.6	28.4				
	F-6N			2.6	1.5	3/8" Female NPT	63.5	31.8	31.8												
	F-6R			2.6	1.5	3/8" ISO Female Tapered	63.5	31.8	-												
SBV4	S-8T	10.3	0.406	12.0	4.6	1/2" S-LOK	99.6	49.8	44.2												
	S-12T			6.4	3.8	3/4" S-LOK	99.6	49.8	44.2												
	S-12M	9.5	0.375	12.0	4.6	12mm S-LOK	99.6	49.8	44.2	17.5	17.5	76.2	9.5	3.0	38.1	61.7	38.1				
	F-8N			6.3	3.5	1/2" Female NPT	79.2	39.6	39.6												
	F-8R			10.3	0.406	6.3	3.5	1/2" ISO Female Tapered	79.2	39.6	-										
	F-8R					6.3	3.5	1/2" ISO Female Tapered	79.2	39.6	-										

All dimensions shown are for reference only and are subject to change. Dimensions with S-LOK nuts are in finger-tight position. Patterns : To order angle pattern, use-A as a suffix to the basic ordering number. Example : SBV1-S-4T-A-S

Flow Rate

Pressure Drop to Atmosphere (Δp) in psi	Cv															
	0.1	0.2	0.5	0.6	0.9	1.2	1.5	1.6	2.4	2.6	3.0	6.0	6.3	6.4	12.0	
Air SCFM @70°F(21°C)	10	1.1	2.7	6.9	8.3	12.0	17.0	21.0	22.0	33.0	36.0	41.5	83.0	87.2	88.6	166.0
	50	3.0	7.6	19.1	23.0	34.0	46.0	57.0	61.0	92.0	99.5	115.0	230.0	241.0	245.0	459.0
	100	5.3	14.0	33.9	40.7	61.0	81.0	100.0	110.0	160.0	176.0	203.0	407.0	427.0	434.0	814.0
Water US GPM @70°F(21°C)	10	0.3	0.6	1.6	1.9	2.8	3.7	4.7	5.0	7.5	8.2	9.5	19.0	19.9	20.2	37.9
	50	0.7	1.4	3.5	4.2	6.3	8.4	11.0	11.0	17.0	18.4	21.2	42.3	44.5	45.3	84.9
	100	1.0	2.0	5.0	6.0	9.0	12.0	15.0	16.0	24.0	26.0	30.0	60.0	63.0	64.0	120.0

The Cv is for the straight pattern valves, Cvs of angle pattern valves are the same as those of 3-way valves.

3-Way switching Valves

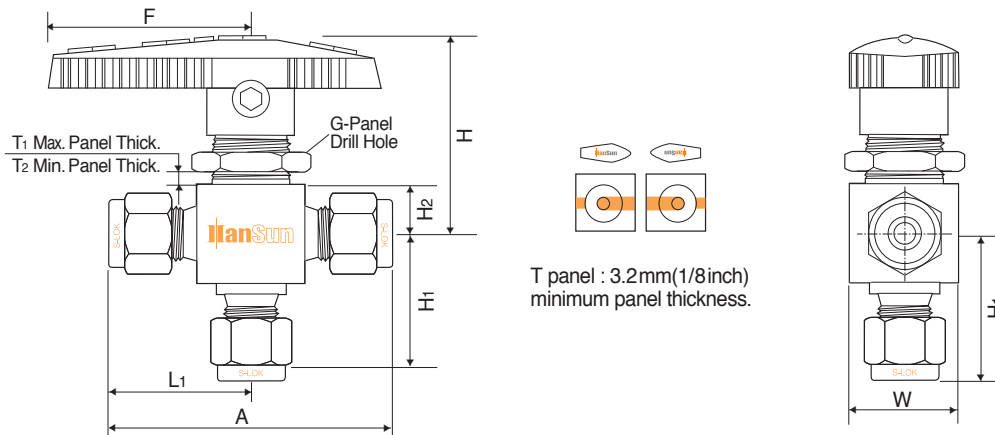

Ordering Information and Dimensions

Basic Ordering Number		Orifice		Cv	End Connections	Dimensions (mm)									
		mm	inch			A	L1	H1	H2	F	T1	T2	G	H	W
SBV1-3B	S-1T	1.3	0.052	0.08	1/16" S-LOK	42.7	21.3	20.6	8.6	28.7	6.4	2.0	15.1	34.5	14.7
	S-2T	2.4	0.093	0.15	1/8" S-LOK	51.1	25.6	24.6							
	S-4T	3.2	0.125	0.35	1/4" S-LOK	56.1	28.1	27.2							
	S-3M	2.4	0.093	0.15	3mm S-LOK	51.1	25.6	24.6							
	S-6M	3.2	0.125	0.35	6mm S-LOK	56.1	28.1	27.2							
	F-2N	3.2	0.125	0.3	1/8" Female NPT	41.1	20.6	20.6							
SBV2-3B	S-4T	4.8	0.187	0.90	1/4" S-LOK	60.7	30.4	29.7	11.2	38.9	4.8	2.5	19.8	39.6	19.8
	S-6M			0.90	6mm S-LOK	60.7	30.4	29.7							
	S-8M			0.90	8mm S-LOK	62.5	31.2	30.5							
	F-4N			0.75	1/4" Female NPT	52.3	26.2	26.2							
	F-4R			0.75	1/4" ISO Female Tapered	52.3	26.2	26.2							
SBV3-3B	S-6T	7.1	0.281	2.0	3/8" S-LOK	73.4	36.7	36.3	14.2	50.8	9.5	3.0	28.6	52.6	28.4
	S-10M			2.0	10mm S-LOK	73.4	36.7	36.3							
	F-4N			1.7	1/4" Female NPT	63.5	31.8	31.8							
	F-6N			1.5	3/8" Female NPT	63.5	31.8	31.8							
	F-6R			1.5	3/8" ISO Female Tapered	63.5	31.8	31.8							
SBV4-3B	S-8T	10.3	0.406	4.6	1/2" S-LOK	88.4	44.2	44.2	17.5	76.2	9.5	3.0	38.1	61.7	38.1
	S-12T	10.3	0.406	3.8	3/4" S-LOK	88.4	44.2	44.2							
	S-12M	9.5	0.375	4.6	12mm S-LOK	88.4	44.2	44.2							
	F-8N	10.3	0.406	3.5	1/2" Female NPT	79.5	39.8	39.6							
	F-8R	10.3	0.406	3.5	1/2" ISO Female Tapered	79.5	39.8	39.6							

All dimensions shown are for reference only and are subject to change. Dimensions with S-LOK nuts are in finger-tight position.

• Flow Rate

Pressure Drop to Atmosphere (ΔP) in psi		Cv												
		0.08	0.15	0.30	0.35	0.75	0.8	0.9	1.5	1.7	2.0	3.5	3.8	4.6
Air SCFM @70°F(21°C)	10	0.9	2.0	4.2	4.8	10.0	11.0	12.0	20.8	23.5	27.7	48.4	52.6	63.7
	50	2.4	5.7	11.5	13.4	29.0	31.0	34.0	57.4	65.0	76.5	134.0	145.0	176.0
	100	4.3	10.1	20.3	23.7	51.0	54.0	61.0	102.0	115.0	136.0	237.0	258.0	312.0
Water US GPM @70°F(21°C)	10	0.3	0.4	0.9	1.1	2.3	2.5	2.8	4.7	5.4	6.3	11.1	12.0	14.5
	50	0.6	1.0	2.1	2.5	5.3	5.6	6.3	10.6	12.0	14.1	24.7	26.9	32.5
	100	0.8	1.5	3.0	3.5	7.5	8.0	9.0	15.0	17.0	20.0	35.0	38.0	46.0

Packing Adjustment

- SBV30 valves are designed to control fluid in full open and closed position ; using SBV30 valves to throttle the flow may reduce the valve life.
- Every valves are factory adjusted for 1000psig service at 70°F(21°C).
- For use in higher pressure, the packing must be readjusted.
- Exposure of valves to varying temperature can affect the initial packing load. You may need check leak and readjust packing bolt.
- Packing adjustment may be required during the valve in service.

Vent Hole Option

: Downstream vent hole is open used with instrument or gauges. When the valve is in the on position, pessure is applied to the Gauge or instrument.
 When the valve is turned off, the instrument or gauge is vented to atmosphere through a hole in the side of the valve body and upstream port is closed to fluid flow. The maximum working pressure of the valve with the vented hole Option is limited to 500psig (34bar).

Testing

- Every valve is factory tested for bubble-tight leakage at both seat and stem packing with nitrogen at 1000psi (69bar).
- Seats have a maximum allowable leak rate of 0.1 sccm. Optional tests are available upon request.

• Ordering Information

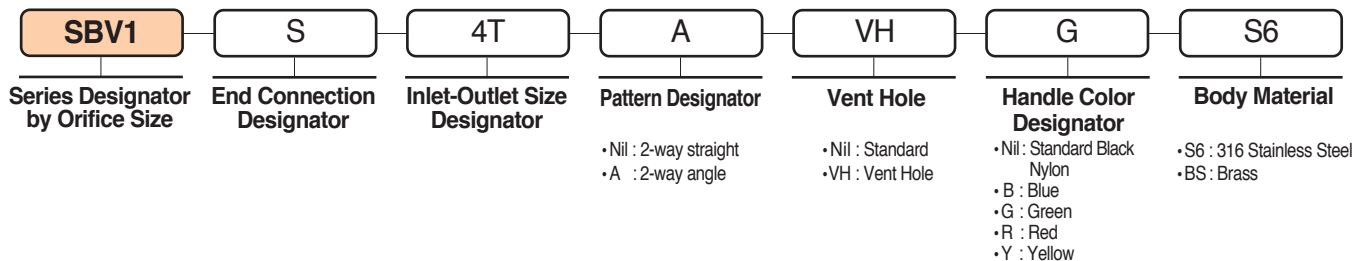

SAFETY in VALVE SELECTION

When selecting a valve, the total system design must be considered to ensure safe, trouble-free performance. Valve function, materials compatibility, adequate ratings, proper installation, operation, and maintenance are the responsibility of the system designer and user.