



Hansun

한선엔지니어링(주)
HANSUN ENGINEERING CO., LTD.

FORGED FITTINGS

HANSUN ENGINEERING CO.,LTD. specializing in the manufacture of hydraulic pipe, has begun home production of pipe clamp, the first of its kind in Korea. We have produced top-notch products with a high performance, the most optimum standard, and good durability, based on a harmony of technological expertise and years of field experience. Various certifications at home and overseas proves our unparalleled competency in this field, and HANSUN ENGINEERING CO., LTD. will devote ourselves in growing up into an international-reputed international-reputed, A-1 company in the world, with management principles of "The Highest Technology", "Customer's Satisfaction" and "Dominance of the World Market".





With an invaluable pride of producing pipe clamp initially in Korea, we won't forget the attitude of outrunner to meet the needs of customers. We have supplied over-all materials used in piping, ranging from Clamp to Flange, Fitting and Valve. All the products made in an unique system of Saehan Entech have drawn attraction of customers oversea as well as domestic ones.

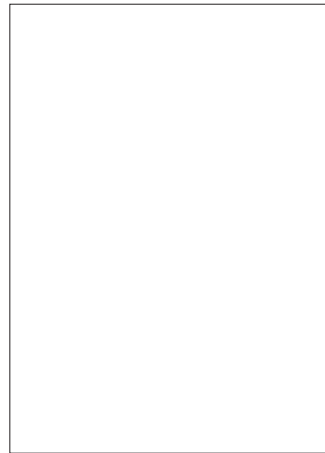
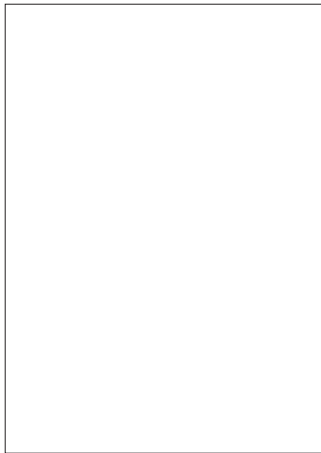
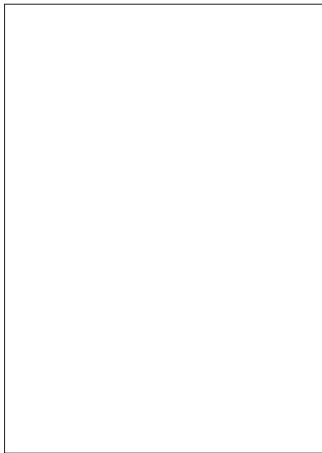

CONTENTS

KS B 1542 (JIS B2316)
ANSI B16.11

Socket-Welding Type

90° 45° Elbow	10
Tee, Cross	11
Coupling, Half Coupling	12
Cap, Boss	13
Union	14
Male Connector	15
Reducer Insert	16
Reducing Coupling, Boss Type R	17

Threaded Type

90° 45° Elbow	18
Tee, Cross	19
Coupling, Half Coupling, Cap	20
Pulg, Reducing Coupling	21
Hex Nipple, Reducer Nipple, Hex Socket	22
Hex Bushing, Boss Type A, Boss Type R	23
Union	24

Outlet

Weldolet	25
Socket, Thredolet	26
Nippolet, Swaged Nipple	27

Technical Data

Forged Socket Welding Threaded Fitting Bore, Tolerance	28
KS B0222 & JIS B0203 Pipe Threads. (Except Dryseal)	29
ANSI B2.1 Taper Pipe Threads	30,31
Wall Thickness Schedules	32,33
Material Specifications	34

VISUAL INDEX

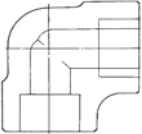
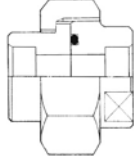
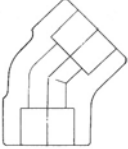
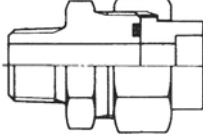
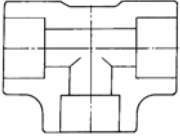
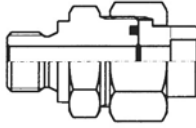
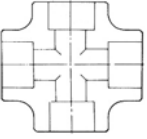
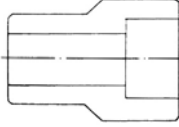
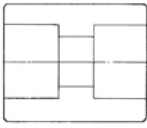
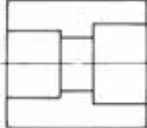
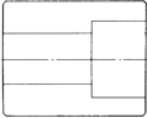
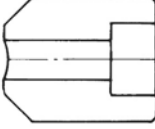
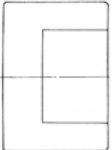
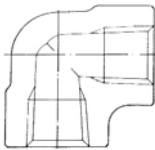
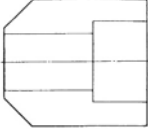
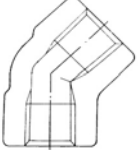
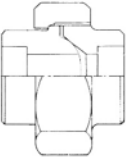
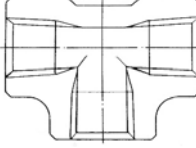
	90° Elbow SWLA	10		Union SWUAO	14
	45° Elbow SWLB	10		Male Connector SWMC-R	15
	Tee SWTA	11		Male Connector SWMC-G	15
	Cross SWXA	11		Reducing Insert SWRM	16
	Full Coupling SWFC	12		Reducing Coupling SWRC	17
	Half Coupling SWHC	12		Boss Type R SWBR	17
	Cap SWCA	13		90° Elbow SLA	18
	Boss SWBA	13		45° Elbow SLB	18
	Union SWUA	14		Tee STA	19

VISUAL INDEX

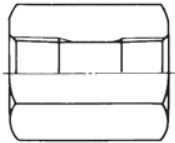
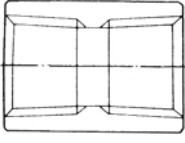
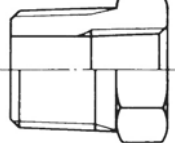
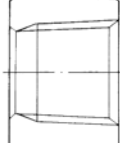
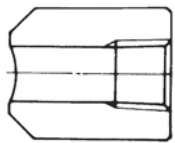
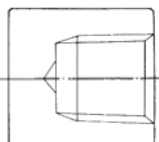
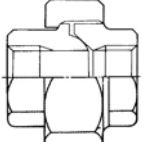
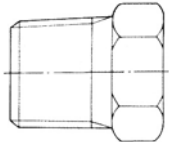
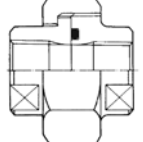
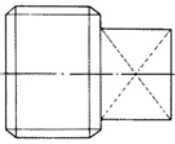
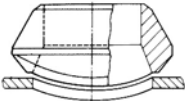
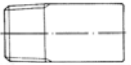
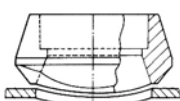
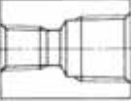
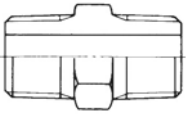
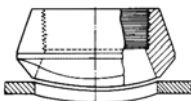
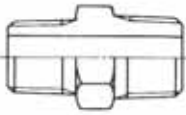
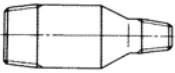
	Cross STX	19		Hex Socket SSA	22
	Full Coupling SFC	20		Hex Bushing SHB	23
	Half Coupling SHC	20		Boss SBR	23
	Cap SCA	20		Union SUA	24
	Hex Head Pulg SPB	21		Union SUA0	24
	Squire Pulg SPD	21		Weldolet SWLT	25
	Round Plug SPE	21		Sockolet STLT	26
	Reducing Coupling SRC				
	Hex Nipple SNA	22		Threadolet STLA	26
	Reducing Nipple SNR	22		Swage Nipple	27

SOCKET WELDING & THREADED FITTINGS

1. Pressure Ratings

These fittings shall be designated as pressure class 2000, 3000 And 6000 fittings for threading and pressure class 3000,6000 and 9000 for socket-welding. This designation identifies the fittings with their ratings as shown as follow, Table 1.

Table 1:Correlation of Fittings Class With Schedule Number of Wall Designation of Pipe for Calculation of Ratings.

Pressure Class Designation of Fitting	Type of Fitting	Pipe Used for Rating Basic	
		Schedule No.	Wall Designation
2000 lb	Threaded	80	X-S
3000 lb	Threaded	160	-
6000 lb	Threaded	-	XX-S
3000 lb	Socket-Welding	80	X-S
6000 lb	Socket-Welding	160	-
9000 lb	Socket-Welding	-	XX-S

*This table is not intended to restrict the use of pipe of thinner or thicker wall with fittings.

Pipe actually used may be thinner or thicker in nominal wall than that shown in Table 1.

When tinner pipe is used its strength may govern the rating.

When thicker pipe is used (e.g., for mechanical strength) the strength of the fitting governs the rating.

Table 2:Nominal wall thickness of Schedule 160 and Double Extra Strong Pipe.

NPS.	Schedule 160		XX-S	
	in	mm	in	mm
½	0.124	3.15	0.190	4.83
¾	0.145	3.68	0.230	6.05
¾	0.158	4.01	0.252	6.40

Table 3: Pressure/ Temperature Ratings Non-shock Working Pressure in Pounds per Square Inch

Service Temperature Degree °F	2000lb Threaded Fittings					3000lb Socket Welding and Threaded Fittings					6000lb Socket Welding and Threaded Fittings				
	Carbon steel	F304	F316	F22	F5	Carbon steel	F304	F316	F22	F5	Carbon steel	F304	F316	F22	F5
100	2000	1715	2000	2000	2000	3000	2570	3000	3000	3000	6000	5145	6000	6000	6000
150	1970	1615	1970	1970	1970	2950	2425	2950	2950	2950	5915	4855	5915	5915	5915
200	1940	1520	1940	1940	1940	2915	2280	2915	2915	2915	5830	4565	5830	5830	5830
250	1915	1445	1915	1915	1915	2875	2170	2975	2975	2975	5750	4340	5750	5750	5750
300	1975	1370	1896	1895	1895	2845	2055	2845	2845	2845	5690	4115	5690	5690	5690
350	1875	1310	1875	1875	1875	2810	1965	2810	2810	2810	5625	3930	5690	5625	5625
400	1850	1245	1850	1850	1850	2775	1870	2775	2775	2775	5550	3745	5550	5550	5550
450	1810	1195	1810	1710	1810	2715	1790	2715	2715	2715	5430	3585	5430	5430	5430
500	1735	1140	1735	1635	1735	2605	1715	2605	2605	2605	5210	3430	5210	5210	5210
550	1640	1100	1640	1540	1640	2460	1650	2460	2460	2460	4925	3305	4925	4925	4925
600	1540	1060	1540	1440	1540	2310	1590	2310	2310	2310	4620	3180	4620	4620	4620
650	1430	1020	1430	1330	1430	2150	1535	2150	2150	2150	4300	3070	4300	4300	4300
700	1305	985	1370	1240	1340	1960	1480	2055	2010	2010	3920	2960	4110	4025	4025
750	1180	950	1305	1145	1245	1775	1425	1960	1870	1870	3550	2850	3920	3745	3745
800	1015	915	1240	1055	1155	1525	1370	1865	1735	1735	3050	2745	3730	3470	3470
850	830	880	1180	1060	1060	1250	1330	1770	1595	1595	2500	2660	3540	3190	3190
900	615	860	1115	970	970	925	1290	1675	1455	1455	1885	2580	3350	2915	2915
950	425	845	1055	880	880	640	1270	1580	1320	1320	1295	2540	3165	2640	2640
1000	235	830	990	740	695	350	1250	1485	1115	1240	715	2500	2975	2230	2085

2. Size Identification

The size of a fitting is identified by the nominal pipe size.

For reducing fittings, the size of the largest run opening is to be given first, followed by the size of the opening opposite of the same run. The branch size of a Tee is given last.

Where the case is a Cross, the largest side-outlet is thirdly given, then the opening opposite.

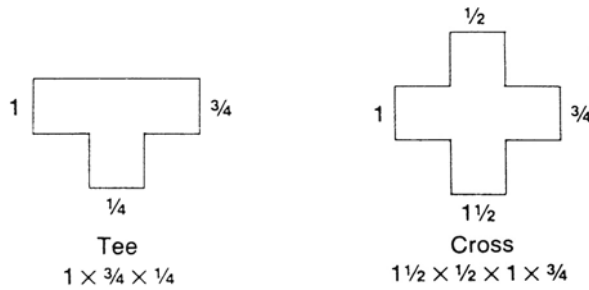

3. Threads

Unless otherwise specified in inquiry, all threaded fittings are supplied with NPT threads (ANSI B2.1 American Standard Taper Pipe Thread) for reference, other available threads are:

- ISO/R7, Pipe Threads for Gas List Tubes and Screwed Fittings where Pressure-tight Joints are made on the threads (BS 2.1 & JIS B0203PT Thread).
- API 5B, Line Pipe Threads.
- KSB0222 Taper Pipe Threads

■ 90° Elbow (SWLA)

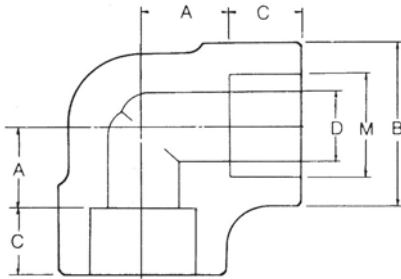

Part No.	Size	M	B	D	A	C	Unit Weight (kg)
3000 lb							
SWLA80-02	¼	See Note (1) To be specified by purchaser	23	9.4	11.1	10	0.132
SWLA80-03	⅜		26.5	12.7	13.4	10	0.113
SWLA80-04	½		34.0	16.1	16.0	13	0.226
SWLA80-06	¾		38.5	21.2	20.0	16	0.312
SWLA80-08	1		46.5	27.0	23.0	16	0.596
SWLA80-10	1¼		56.5	35.4	28.0	18	0.709
SWLA80-12	1½		63.5	41.2	33.0	20	0.850
SWLA80-16	2		76.0	52.7	40.0	22	1.474
SWLA80-20	2½		92.0	62.7	42.0	24	2.460
SWLA80-24	3		110.0	78.0	57.1	31.5	4.650
SWLA80-32	4	146.0	102.0	70.0	45	9.410	
6000 lb							
SWLA160-04	½	See Note (1)	38.5	12.0	20.0	16	0.425
SWLA160-06	¾		46.5	15.8	23.0	16	0.652
SWLA160-08	1		56.5	21.0	28.0	18	1.020
SWLA160-10	1¼		63.5	29.7	33.0	20	1.446
SWLA160-12	1½		76.0	34.2	40.0	22	2.380
SWLA160-16	2		92.0	43.1	42.0	24	3.760
SWLA160-20	2½		110.0	54.0	57.1	24	6.120
SWLA160-24	3		121.0	67.7	66.0	31.5	8.760
SWLA160-32	4		152.0	87.0	70.0	45	14.300
9000 lb							
SWLAXXS-04	½	See Note (1)	46.5	6.4	23.0	16	0.510
SWLAXXS-06	¾		56.5	11.0	28.0	16	0.782
SWLAXXS-08	1		63.5	15.2	33.0	18	1.224
SWLAXXS-10	1¼		76.0	22.7	40.0	20	1.807
SWLAXXS-12	1½		92.0	27.9	42.0	22	2.975
SWLAXXS-16	2		110.0	38.1	54.0	24	4.700
SWLAXXS-20	2½		121.0	45.0	66.0	24	10.512
SWLAXXS-24	3		146.0	58.4	70.0	31.5	13.020

■ 45° Elbow (SWLB)

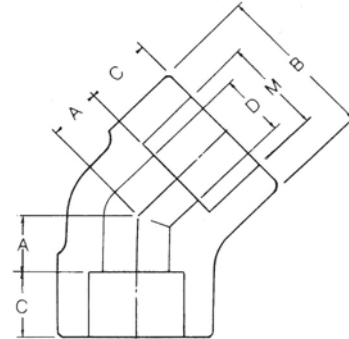

Part No.	Size	M	B	D	A	C	Unit Weight (kg)
3000 lb							
SWLB80-02	¼	See Note (1) To be specified by purchaser	23	9.4	7.9	10	0.093
SWLB80-03	⅜		26.5	12.7	7.9	10	0.142
SWLB80-04	½		34.0	16.1	13.0	13	0.264
SWLB80-06	¾		38.5	21.2	13.0	14	0.397
SWLB80-08	1		46.5	27.0	14.0	16	0.624
SWLB80-10	1¼		56.5	35.4	18.0	18	0.907
SWLB80-12	1½		63.5	41.2	22.0	20	0.782
SWLB80-16	2		76.0	52.7	24.0	22	1.265
SWLB80-20	2½		92.0	62.7	29.0	24	3.062
SWLB80-24	3		110.0	78.0	34.0	31.5	4.763
SWLB80-32	4	146.0	102.0	42.0	45	8.250	
6000 lb							
SWLB160-04	½	See Note (1)	38.5	12.0	13	16	0.397
SWLB160-06	¾		46.5	15.8	14	16	0.595
SWLB160-08	1		56.5	21.0	22	18	0.935
SWLB160-10	1¼		63.5	29.7	22	20	1.157
SWLB160-12	1½		76.0	34.2	24	22	1.982
SWLB160-16	2		92.0	43.1	29	24	4.000
SWLB160-20	2½		110.0	54.0	34	24	5.875
SWLB160-24	3		121.0	67.7	34	31.5	6.509
SWLB160-32	4		152.0	87.0	42	45	12.360
9000 lb							
SWLBXXS-04	½	See Note (1)	46.5	6.4	14	16	0.875
SWLBXXS-06	¾		56.5	11.0	22	16	1.369
SWLBXXS-08	1		63.5	15.2	22	18	1.725
SWLBXXS-10	1¼		76.0	22.7	24	20	2.931
SWLBXXS-12	1½		92.0	27.9	29	22	5.062
SWLBXXS-16	2		110.0	38.1	34	24	6.400
SWLBXXS-20	2½		121.0	45.0	34	24	7.925
SWLBXXS-24	3		146.0	58.4	42	31.5	11.569

- Note
- (1) For the 'Bore'(M) other than standard pipe outside diameter.
- Dimensions are in millimeters.
- Dimensional Tolerances See ANSI B16.11 or JIS B2316

■ Tee (SWTA)

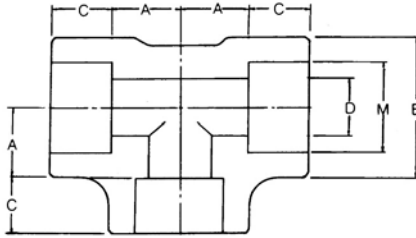

Part No.	Size	M	B	D	A	C	Unit Weight (kg)
3000 lb							
SWTA80-02	¼	See Note (1) To be specified by purchaser	23	9.4	11.1	10	0.161
SWTA80-03	⅜		26.5	12.7	13.4	10	0.142
SWTA80-04	½		34.0	16.1	16.0	13	0.170
SWTA80-06	¾		38.5	21.2	20.0	16	0.397
SWTA80-08	1		46.5	27.0	23.0	16	0.624
SWTA80-10	1¼		56.5	35.4	28.0	18	0.907
SWTA80-12	1½		63.5	41.2	33.0	20	1.134
SWTA80-16	2		76.0	52.7	40.0	22	1.701
SWTA80-20	2½	92.0	62.7	42.0	24	3.424	
SWTA80-24	3	110.0	78.0	57.1	31.5	5.670	
SWTA80-32	4	146.0	102.0	70.0	45	12.247	
6000 lb							
SWTA160-04	½	See Note (1)	38.5	12.0	20.0	16	0.623
SWTA160-06	¾		46.5	15.8	23.0	16	0.907
SWTA160-08	1		56.5	21.0	28.0	18	1.503
SWTA160-10	1¼		63.5	29.7	33.0	20	1.701
SWTA160-12	1½		76.0	34.2	40.0	22	2.948
SWTA160-16	2		92.0	43.1	42.0	24	3.702
SWTA160-20	2½		110.0	54.0	57.1	24	8.723
SWTA160-24	3		121.0	67.7	66.0	31.5	10.660
SWTA160-32	4	152.0	87.0	70.0	45	19.020	
9000 lb							
SWLAXXS-04	½	See Note (1)	46.5	6.4	23.0	16	0.779
SWLAXXS-06	¾		56.5	11.0	28.0	16	1.333
SWLAXXS-08	1		63.5	15.2	33.0	18	1.879
SWLAXXS-10	1¼		76.0	22.7	40.0	20	2.126
SWLAXXS-12	1½		92.0	27.9	42.0	22	3.685
SWLAXXS-16	2		110.0	38.1	54.0	24	4.627
SWLAXXS-20	2½		121.0	45.0	66.0	24	10.903
SWLAXXS-24	3		146.0	58.4	70.0	31.5	13.325

■ Cross (SWXA)

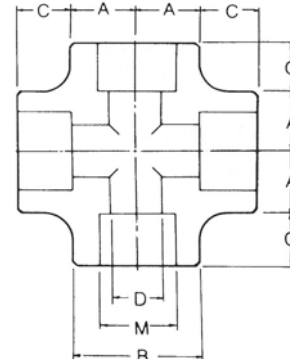

Part No.	Size	M	B	D	A	C	Unit Weight (kg)
3000 lb							
SWXA80-02	¼	See Note (1) To be specified by purchaser	23	9.4	11.1	10	0.182
SWXA80-03	⅜		26.5	12.7	13.4	10	0.170
SWXA80-04	½		34.0	16.1	16.0	13	0.368
SWXA80-06	¾		38.5	21.2	20.0	16	0.519
SWXA80-08	1		46.5	27.0	23.0	16	0.680
SWXA80-10	1¼		56.5	35.4	28.0	18	1.020
SWXA80-12	1½		63.5	41.2	33.0	20	1.389
SWXA80-16	2		76.0	52.7	40.0	22	2.326
SWXA80-20	2½	92.0	62.7	42.0	24	7.484	
SWXA80-24	3	110.0	78.0	57.1	31.5	10.432	
SWXA80-32	4	146.0	102.0	70.0	45	18.144	
6000 lb							
SWXA160-04	½	See Note (1)	38.5	12.0	20.0	16	0.660
SWXA160-06	¾		46.5	15.8	23.0	16	1.120
SWXA160-08	1		56.5	21.0	28.0	18	1.730
SWXA160-10	1¼		63.5	29.7	33.0	20	2.381
SWXA160-12	1½		76.0	34.2	40.0	22	3.750
SWXA160-16	2		92.0	43.1	42.0	24	7.860
SWXA160-20	2½		110.0	54.0	57.1	24	10.600
SWXA160-24	3		121.0	67.7	66.0	31.5	13.600
SWXA160-32	4	152.0	87.0	70.0	45	26.000	
9000 lb							
SWLAXXS-04	½	See Note (1)	46.5	6.4	23.0	16	1.615
SWLAXXS-06	¾		56.5	11.0	28.0	16	2.113
SWLAXXS-08	1		63.5	15.2	33.0	18	3.896
SWLAXXS-10	1¼		76.0	22.7	40.0	20	6.298
SWLAXXS-12	1½		92.0	27.9	42.0	22	9.280
SWLAXXS-16	2		110.0	38.1	54.0	24	18.741
SWLAXXS-20	2½		121.0	45.0	66.0	24	25.702
SWLAXXS-24	3		146.0	58.4	70.0	31.5	33.761

- Note
- (1) For the 'Bore'(M) other than standard pipe outside diameter.
- Dimensions are in millimeters.
- Dimensional Tolerances See ANSI B16.11 or JIS B2316

■ Full Couplong (SWFC)

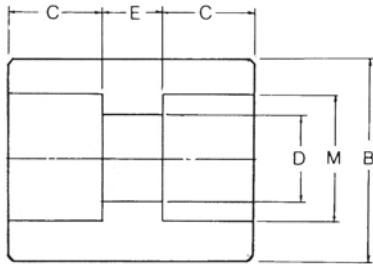

■ Half Coupling (SWHC)

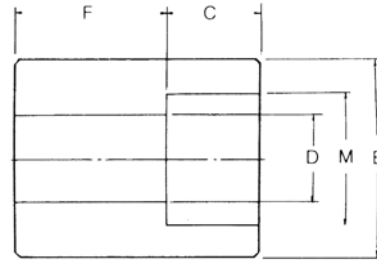

Part No.	Size	M	B	D	C	E	Unit Weight (kg)
----------	------	---	---	---	---	---	------------------

3000 lb

SWFC80-02	¼	See Note (1) To be specified by purchaser	22.0	9.4	10	6.4	0.05
SWFC80-03	⅜		26.0	12.7	10	6.4	0.12
SWFC80-04	½		32.0	16.1	10	9.6	0.12
SWFC80-06	¾		38.0	21.2	13	9.6	0.18
SWFC80-08	1		46.0	27.0	13	12.7	0.26
SWFC80-10	1¼		55.0	35.4	13	12.7	0.35
SWFC80-12	1½		63.0	41.2	13	12.7	0.47
SWFC80-16	2		75.0	52.7	16	19.1	0.81
SWFC80-20	2½		95.0	65.3	16	19.1	1.25
SWFC80-24	3		110.0	78.0	16	19.1	1.53
SWFC80-32	4	140.0	102.0	19	19.1	2.91	

6000 lb

SWFC160-04	½	See Note (1)	35.0	12.0	10	9.6	0.170
SWFC160-06	¾		42.0	15.8	13	9.6	0.249
SWFC160-08	1		50.0	21.0	13	12.7	0.420
SWFC160-10	1¼		60.0	29.7	13	12.7	0.525
SWFC160-12	1½		68.0	34.2	13	12.7	0.665
SWFC160-16	2		85.0	43.1	16	19.1	1.240
SWFC160-20	2½		100.0	54.0	16	19.1	1.640
SWFC160-24	3		114.3	67.7	16	19.1	2.746
SWFC160-32	4		160.0	87.0	19	19.1	4.679

9000 lb

SWFCXXS-04	½	See Note (1)	42.0	6.4	10	9.6	0.270
SWFCXXS-06	¾		48.0	11.0	13	9.6	0.327
SWFCXXS-08	1		60.0	15.2	13	12.7	0.518
SWFCXXS-10	1¼		70.0	22.7	13	12.7	0.813
SWFCXXS-12	1½		75.0	27.9	13	12.7	0.940
SWFCXXS-16	2		90.0	38.1	16	19.1	1.553
SWFCXXS-20	2½		110.0	45.0	16	19.1	2.430
SWFCXXS-24	3		130.0	58.5	16	19.1	3.721
SWFCXXS-32	4		160.0	80.3	19	19.1	5.137

Part No.	Size	M	B	D	C	F	Unit Weight (kg)
----------	------	---	---	---	---	---	------------------

3000 lb

SWHC80-02	¼	See Note (1) To be specified by purchaser	22.0	9.4	10	15.7	0.058
SWHC80-03	⅜		26.0	12.7	10	17.5	0.073
SWHC80-04	½		32.0	16.1	10	22.4	0.138
SWHC80-06	¾		38.0	21.2	13	23.9	0.203
SWHC80-08	1		46.0	27.0	13	28.4	0.313
SWHC80-10	1¼		55.0	35.4	13	30.2	0.431
SWHC80-12	1½		63.0	41.2	13	31.8	0.593
SWHC80-16	2		75.0	52.7	16	41.1	1.280
SWHC80-20	2½		95.0	62.7	16	42.9	1.490
SWHC80-24	3		110.0	78.0	16	44.5	2.202
SWHC80-32	4	140.0	102.0	19	47.7	4.250	

6000 lb

SWHC160-04	½	See Note (1)	35.0	12.0	10	22.4	0.193
SWHC160-06	¾		42.0	15.8	13	23.9	0.284
SWHC160-08	1		50.0	21.0	13	28.4	0.488
SWHC160-10	1¼		60.0	29.7	13	30.2	0.583
SWHC160-12	1½		68.0	34.2	13	31.8	0.640
SWHC160-16	2		85.0	43.1	16	41.1	1.726
SWHC160-20	2½		100.0	54.0	16	42.9	2.247
SWHC160-24	3		114.3	67.7	16	44.5	3.412
SWHC160-32	4		160.0	87.0	19	47.7	5.730

9000 lb

SWHCXXS-04	½	See Note (1)	40.4	42.0	10	22.4	0.312
SWHCXXS-06	¾		45.5	48.0	13	23.9	0.389
SWHCXXS-08	1		55.0	60.0	13	28.4	0.641
SWHCXXS-10	1¼		66.5	70.0	13	30.2	0.980
SWHCXXS-12	1½		73.0	75.0	13	31.8	1.179
SWHCXXS-16	2		88.0	90.0	16	41.1	1.994
SWHCXXS-20	2½		108.0	110.0	16	42.9	3.210
SWHCXXS-24	3		127.0	130.0	16	44.5	4.597
SWHCXXS-32	4		160.0	160.0	19	47.7	7.610

- Note
- (1) For the 'Bore'(M) other than standard pipe outside diameter.
- Dimensions are in millimeters.
- Dimensional Tolerances See ANSI B16.11 or JIS B2316

■ Cap (SWCA)

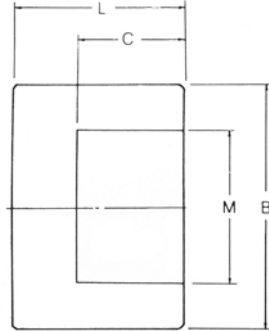

Part No.	Size	M	B	C	L	Unit Weight (kg)
----------	------	---	---	---	---	------------------

3000 lb						
SWCA80-02	¼	See Note (1) To be specified by purchaser	22.0	10	20	0.048
SWCA80-03	⅜		26.0	10	20	0.076
SWCA80-04	½		32.0	10	20	0.100
SWCA80-06	¾		38.0	13	25	0.182
SWCA80-08	1		46.0	13	27	0.241
SWCA80-10	1¼		55.0	13	30	0.350
SWCA80-12	1½		63.0	13	30	0.612
SWCA80-16	2		75.0	16	36	0.880
SWCA80-20	2½		95.0	16	42	1.520
SWCA80-24	3		110.0	16	46	2.208
SWCA80-32	4	140.0	19	55	4.417	

6000 lb						
SWCA160-04	½	See Note (1)	35.0	10	26	0.055
SWCA160-06	¾		42.0	13	27	0.223
SWCA160-08	1		50.0	13	30	0.382
SWCA160-10	1¼		60.0	13	35	0.511
SWCA160-12	1½		60.0	13	36	0.735
SWCA160-16	2		85.0	16	39	1.289
SWCA160-20	2½		100.0	16	45	2.056
SWCA160-24	3		114.3	16	52	3.364

9000 lb						
SWCAXXS-04	½	See Note (1)	42.0	10	30	0.262
SWCAXXS-06	¾		48.0	13	30	0.320
SWCAXXS-08	1		60.0	13	33	0.520
SWCAXXS-10	1¼		70.0	13	40	1.256
SWCAXXS-12	1½		75.0	13	40	1.440
SWCAXXS-16	2		90.0	16	43	1.686
SWCAXXS-20	2½		110.0	16	50	2.986
SWCAXXS-24	3		130.0	16	58	4.666

■ Boss (SWBA)

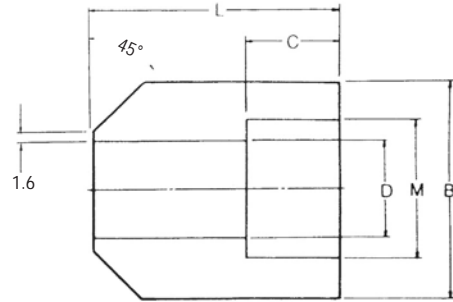

Part No.	Size	M	B	D	C	L	Unit Weight (kg)
----------	------	---	---	---	---	---	------------------

3000 lb							
SWBA80-02	¼	See Note (1)	22.0	9.4	10	30	0.09
SWBA80-03	⅜		26.0	12.7	10	30	0.14
SWBA80-04	½		32.0	16.1	10	33	0.24
SWBA80-06	¾		38.0	21.2	13	35	0.28
SWBA80-08	1		46.0	27.0	13	43	0.41
SWBA80-10	1¼		55.0	35.4	13	46	0.44
SWBA80-12	1½		65.0	41.2	13	50	0.63
SWBA80-16	2		75.0	52.7	16	57	1.09

6000 lb							
SWBA160-04	½	See Note (1)	35.0	12.0	10	33	0.45
SWBA160-06	¾		42.0	15.8	13	35	0.52
SWBA160-08	1		55.0	21.0	13	43	0.73
SWBA160-10	1¼		60.0	29.7	13	46	0.77
SWBA160-12	1½		70.0	34.2	13	50	0.12
SWBA160-16	2		85.0	43.1	16	57	1.82

- Note
- (1) For the 'Bore'(M) other than standard pipe outside diameter.
- Dimensions are in millimeters.
- Dimensional Tolerances See ANSI B16.11 or JIS B2316

■ R.J Union (SWUA)

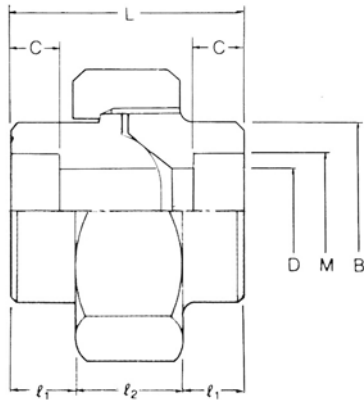

Part No.	Size	M	B	¹	²	L	C	D	H	Unit Weight (kg)
3000 lb										
SWUA80-02	¼	See Note (1) To be specified by purchaser	21.0	11.5	18	41	10.0	9.4	35 HEX	0.187
SWUA80-03	⅜		25.0	14.0	18	46	10.0	12.7	40 HEX	0.245
SWUA80-04	½		32.0	15.0	21	51	10.0	16.1	46 HEX	0.430
SWUA80-06	¾		40.0	17.0	23	57	13.0	21.2	58 HEX	0.620
SWUA80-08	1		48.0	19.5	25	64	13.0	27.0	65 HEX	1.030
SWUA80-10	1¼		55.0	22.5	27	72	13.0	35.4	76 OCT	1.150
SWUA80-12	1½		63.5	24.0	30	78	13.0	41.2	83 OCT	1.530
SWUA80-16	2		76.0	26.0	36	88	16.0	52.7	103 OCT	3.050
SWUA80-20	2½		95.0	34.0	42	110	18.0	62.7	124 OCT	5.140
SWUA80-24	3		116.0	37.5	45	120	22.5	78.0	142 OCT	7.120
SWUA80-32	4	148.0	45.0	50	140	25.0	102.0	176 OCT	12.400	
6000 lb										
SWUA160-04	½	See Note (1)	40.0	17.0	23	57	13	12.0	56 HEX	0.62
SWUA160-06	¾		44.5	19.5	25	64	13	15.8	65 HEX	0.94
SWUA160-08	1		51.0	22.5	27	72	13	21.0	74 OCT	1.98
SWUA160-10	1¼		57.2	24.0	30	78	16	29.7	83 OCT	1.41
SWUA160-12	1½		71.5	26.0	36	88	16	34.2	103 OCT	2.75
SWUA160-16	2		90.0	34.0	42	110	16	43.1	124 OCT	5.05
SWUA160-20	2½		105.0	35.0	45	120	18	54.0	150 OCT	6.87
SWUA160-24	3		125.0	45.0	50	140	22	67.7	176 OCT	10.85

■ O-Ring Union (SWUAO)

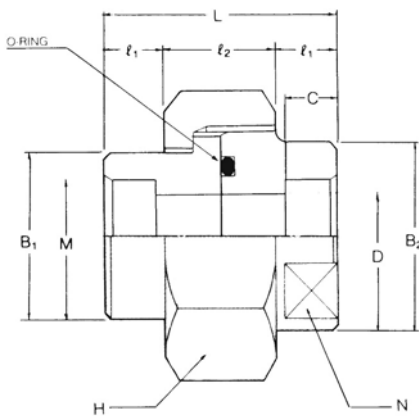

Part No.	Size	M	B ₁	B ₂	D	C	¹	²	L	N	H	O-Ring	Unit Weight (kg)
3000 lb													
SWUAO80-04	½	See Note (1)	22	24	10	10	10	18	38	21	35 HEX	P18	0.160
SWUAO80-06	¾		27	30	12	10	10	18	38	26	41 HEX	P20	0.228
SWUAO80-08	1		32	35	16	10	12	20	44	32	46 HEX	G25	0.328
SWUAO80-10	1¼		38	42	20	13	12	26	50	38	54 HEX	G30	0.535
SWUAO80-12	1½		47	52	25	13	15	26	56	46	63 HEX	G35	0.786
SWUAO80-16	2		56	60	32	13	15	30	60	54	77 HEX	G45	1.104
SWUAO80-20	2½		63	68	38	13	18	36	72	63	80 OCT	G50	1.542
SWUAO80-24	3		76	82	48	17	18	36	72	77	95 OCT	G65	2.080

- Note (1) For the 'Bore'(M) other than standard pipe outside diameter.
- Dimensions are in millimeters.
- Dimensional Tolerances See ANSI B16.11 or JIS B2316

■ SWMC-R

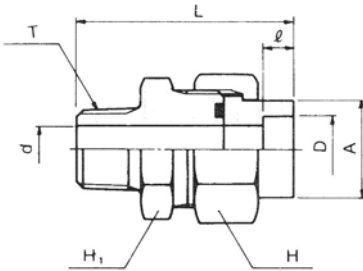

Part No.	Size	D		d	A	L	H	H ₁	T (PT)	O-Ring
SWMC02-02R	¼	14.3	10	7	22	54	HEX 36	HEX 30	¼	P18
SWMC02-03R	¼	14.3	10	9	22	55	HEX 36	HEX 30	⅜	P18
SWMC03-03R	⅜	17.8	10	9	27	56	HEX 41	HEX 36	⅜	P20
SWMC03-04R	⅜	17.8	10	12	27	56	HEX 41	HEX 36	½	P20
SWMC04-04R	½	22.2	10	12	32	60	HEX 46	HEX 41	½	G25
SWMC04-06R	½	22.2	10	16	32	66	HEX 46	HEX 41	¾	G25
SWMC06-06R	¾	27.7	13	16	37	72	HEX 55	HEX 46	¾	G30
SWMC06-08R	¾	27.7	13	20	37	75	HEX 55	HEX 46	1	G30
SWMC08-08R	1	34.5	13	20	44	82	HEX 60	HEX 55	1	G35
SWMC08-10R	1	34.5	13	25	44	84	HEX 60	HEX 55	1¼	G35
SWMC10-10R	1¼	43.2	13	25	54	90	OCT 75	OCT 65	1¼	G45
SWMC10-12R	1¼	43.2	13	32	54	91	OCT 75	OCT 65	1½	G45
SWMC12-12R	1½	49.1	13	32	63	99	OCT 85	OCT 75	1½	G50
SWMC12-16R	1½	49.1	13	38	63	103	OCT 85	OCT 75	2	G50
SWMC16-16R	2	61.1	16	38	76	103	OCT100	OCT 90	2	G65

■ SWMC-G

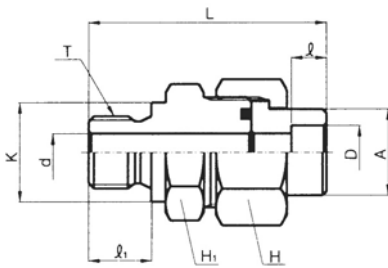

Part No.	Size	D		d	K	A	L	H	H ₁	T (PT)	O-Ring	
SWMC02-02G	¼	14.3	10	7	18	22	12	54	HEX 36	HEX 30	¼	P18
SWMC02-03G	¼	14.3	10	9	21.5	22	12	54	HEX 36	HEX 30	⅜	P18
SWMC03-03G	⅜	17.8	10	9	21.5	27	12	55	HEX 41	HEX 36	⅜	P20
SWMC03-04G	⅜	17.8	10	12	25.5	27	14	57	HEX 41	HEX 36	½	P20
SWMC04-04G	½	22.2	10	12	25.5	32	14	61	HEX 46	HEX 41	½	G25
SWMC04-06G	½	22.2	10	16	31.5	32	16	63	HEX 46	HEX 41	¾	G25
SWMC06-06G	¾	27.7	13	16	31.5	37	16	69	HEX 55	HEX 46	¾	G30
SWMC06-08G	¾	27.7	13	20	38	37	18	73	HEX 55	HEX 46	1	G30
SWMC08-08G	1	34.5	13	20	38	44	18	78	HEX 60	HEX 55	1	G35
SWMC08-10G	1	34.5	13	25	48.5	44	20	80	HEX 60	HEX 55	1¼	G35
SWMC10-10G	1¼	43.2	13	25	48.5	54	20	84	OCT 75	OCT 65	1¼	G45
SWMC10-12G	1¼	43.2	13	32	53.5	54	22	86	OCT 75	OCT 65	1½	G45
SWMC12-12G	1½	49.1	13	32	53.5	63	22	98	OCT 85	OCT 75	1½	G50
SWMC12-16G	1½	49.1	13	38	66	63	24	99	OCT 85	OCT 75	2	G50
SWMC16-16G	2	61.1	16	38	66	76	24	103	OCT100	OCT 90	2	G65

■ Reducing Insert (SWRM)

Type 1

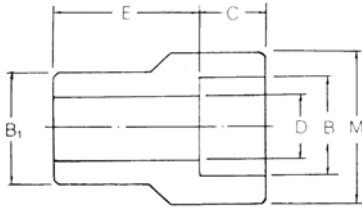

Type 2

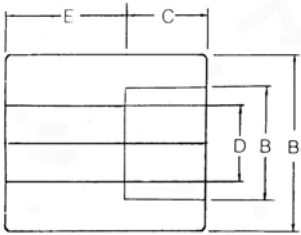

Type 3

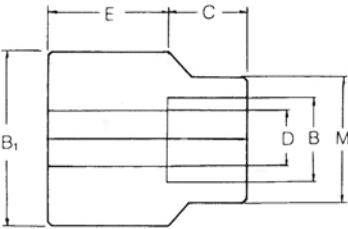

Application of Reducer Insert

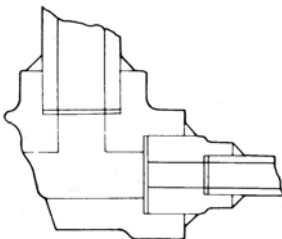

Part No.	Size	Type	M	B ₁	B	C(Min)	E	L	D	Unit Weight (kg)
3000 lb										
SWRM0302-S80	3/8 X 1/4	1	22.2				9.6	21	16	9.4 0.051
SWRM0402-S80	1/2 X 1/4	2	-				9.6	15	-	9.4 0.052
SWRM0403-S80	1/2 X 3/8	1	25.4				9.6	24	20	12.7 0.086
SWRM0602-S80	3/4 X 1/4	3	-				9.6	19	7	9.4 0.109
SWRM0603-S80	3/4 X 3/8	2	-				9.6	19	-	12.7 0.697
SWRM0604-S80	3/4 X 1/2	1	31.8				9.6	26	22	16.1 0.146
SWRM0803-S80	1 X 3/8	3	25.4				9.6	22	7	12.7 0.161
SWRM0804-S80	1 X 1/2	2	-				9.6	22	-	16.1 0.183
SWRM0806-S80	1 X 3/4	1	38.1				12.7	29	23	21.4 0.208
SWRM1004-S80	1 1/4 X 1/2	3	31.8				9.6	24	7	16.1 0.273
SWRM1006-S80	1 1/4 X 3/4	2	-				12.7	24	-	21.4 0.286
SWRM1008-S80	1 1/4 X 1	1	46.0				12.7	32	24.5	27.2 0.436
SWRM1206-S80	1 1/2 X 3/4	3	38.1				12.7	26	8	21.4 0.348
SWRM1208-S80	1 1/2 X 1	2	-				12.7	26	-	27.2 0.384
SWRM1210-S80	1 1/2 X 1 1/4	1	55.0				12.7	35	27	35.5 0.463
SWRM1208-S80	2 X 1	3	46.0				12.7	29	8	27.2 0.615
SWRM1610-S80	2 X 1 1/4	2	-				12.7	29	-	35.5 0.647
SWRM1612-S80	2 X 1 1/2	1	65.0				12.7	37	29	41.2 0.661
SWRM2010-S80	2 1/2 X 1 1/4	3	55.0				12.7	35	8	35.5 1.183
SWRM2012-S80	2 1/2 X 1 1/2	3	65.0				12.7	35	8	41.2 1.107
SWRM2016-S80	2 1/2 X 2	1	76.0				15.9	39	30	52.7 1.200
SWRM2412-S80	3 X 1 1/2	3	65.0				12.7	39	8	41.2 1.715
SWRM2416-S80	3 X 2	3	75.0				15.9	39	10	52.7 1.542
SWRM2420-S80	3 X 2 1/2	1	95.0				15.9	51	33.5	65.9 1.825
6000 lb										
SWRM0302-S160	3/4 X 1/2	1	38.1				12.3	39	23	12.3 0.316
SWRM0402-S160	1 X 1/2	1	38.1				12.3	38	24	12.3 0.354
SWRM0403-S160	1 X 3/4	1	46.0				16.2	43	26	16.2 0.526
SWRM0602-S160	1 1/4 X 1/2	2	-				12.3	29	-	12.3 0.415
SWRM0603-S160	1 1/4 X 3/4	1	46.0				16.2	40	28	16.2 0.557
SWRM0604-S160	1 1/4 X 1	1	55.0				21.2	45	28	21.2 0.765
SWRM0803-S160	1 1/2 X 3/4	2	-				16.2	35	-	16.2 0.619
SWRM0804-S160	1 1/2 X 1	1	55.0				21.2	38	28	21.2 0.723
SWRM0806-S160	1 1/2 X 1 1/4	1	62.0				29.9	52	32	29.9 0.957
SWRM1004-S160	2 X 1	3	-				21.2	43	8	21.2 1.026
SWRM1006-S160	2 X 1 1/4	1	62.0				29.9	54	34	29.9 1.137
SWRM1008-S160	2 X 1 1/2	1	75.0				34.4	63	34	34.4 0.911
SWRM1206-S160	2 1/2 X 1 1/4	3	62.0				29.9	46	8	29.9 1.478
SWRM1208-S160	2 1/2 X 1 1/2	2	-				34.4	46	-	34.4 1.881
SWRM1210-S160	2 1/2 X 2	1	95.0				43.1	73	36	43.1 2.918
SWRM1208-S160	3 X 1 1/2	3	75.0				34.4	50	8	34.4 2.370
SWRM1610-S160	3 X 2	2	95.0				43.1	70	-	43.1 3.313
SWRM1612-S160	3 X 2 1/2	1	110.0				57.3	83	38	57.3 3.562

See Note (1)
To be specified by purchaser

See Note (1)
To be specified by purchaser

See Note (1)

See Note (1)

- Note (1) For the 'Bore'(M) other than standard pipe outside diameter refer to page 32p.
- Dimensions are in millimeters.
- Dimensional Tolerances See ANSI B16.11 or JIS B2316

■ Reducing Coupling (SWRC)

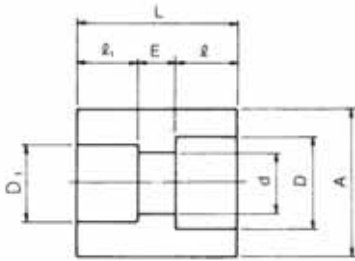

Part No.	Size	D	D ₁			d	A	E	L
3000 lb									
SWRC0302-S80	3/8 X 1/4	17.8	14.3	10	10	9.4	26	6.4	26.4
SWRC0402-S80	1/2 X 1/4	22.2	14.3	10	10	9.4	32	9.5	29.5
SWRC0403-S80	1/2 X 3/8	22.2	17.8	10	10	12.7	32	9.5	29.5
SWRC0602-S80	3/4 X 1/4	27.7	14.3	13	10	9.4	38	9.5	32.5
SWRC0603-S80	3/4 X 3/8	27.7	17.8	13	10	12.7	38	9.5	32.5
SWRC0604-S80	3/4 X 1/2	27.7	22.2	13	10	16.1	38	9.5	32.5
SWRC0803-S80	1 X 3/8	34.5	17.8	13	10	12.7	46	12.7	35.7
SWRC0804-S80	1 X 1/2	34.5	22.2	13	10	16.1	46	12.7	35.7
SWRC0806-S80	1 X 3/4	34.5	27.2	13	13	21.4	46	12.7	38.7
SWRC1004-S80	1 1/4 X 1/2	43.2	22.2	13	10	16.1	55	12.7	35.7
SWRC1006-S80	1 1/4 X 3/4	43.2	27.7	13	13	21.4	55	12.7	38.7
SWRC1008-S80	1 1/4 X 1	43.2	34.5	13	13	27.2	55	12.7	38.7
SWRC1206-S80	1 1/2 X 3/4	49.1	27.7	13	13	21.4	63	12.7	38.7
SWRC1208-S80	1 1/2 X 1	49.1	34.5	13	13	27.2	63	12.7	38.7
SWRC1210-S80	1 1/2 X 1 1/4	49.1	43.2	13	13	35.5	63	12.7	38.7
SWRC1608-S80	2 X 1	61.1	34.5	16	13	27.2	75	19.1	48.1
SWRC1610-S80	2 X 1 1/4	61.1	43.2	16	13	35.5	75	19.1	48.1
SWRC1612-S80	2 X 1 1/2	61.1	49.1	16	13	41.2	75	19.1	48.1
6000 lb									
SWRC0604-S160	3/4 X 1/2	27.7	22.2	13	13	12.3	42	9.5	35.5
SWRC0804-S160	1 X 1/2	34.5	22.2	13	13	12.3	50	12.7	38.7
SWRC0806-S160	1 X 3/4	34.5	27.7	13	13	16.2	50	12.7	38.7
SWRC1004-S160	1 1/4 X 1/2	43.2	22.2	13	13	12.3	60	12.7	38.7
SWRC1006-S160	1 1/4 X 3/4	43.2	27.7	13	13	16.2	60	12.7	38.7
SWRC1008-S160	1 1/4 X 1	43.2	34.5	13	13	21.2	60	12.7	38.7
SWRC1206-S160	1 1/2 X 3/4	49.1	27.7	16	13	16.2	68	12.7	41.7
SWRC1208-S160	1 1/2 X 1	49.1	34.5	16	13	21.2	68	12.7	41.7
SWRC1210-S160	1 1/2 X 1 1/4	49.1	43.2	16	13	29.9	68	12.7	41.7
SWRC1608-S160	2 X 1	61.1	34.5	16	13	21.2	85	19.1	48.1
SWRC1610-S160	2 X 1 1/4	61.1	43.2	16	13	29.9	85	19.1	48.1
SWRC1612-S160	2 X 1 1/2	61.1	49.1	16	16	34.4	85	19.1	51.1

■ Boss Type R (SWBR)

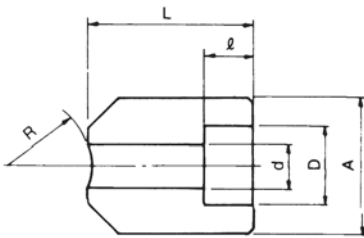

Part No.	Size	D		d	A	R	L
3000 lb							
SWBR02-S80	1/4	14.3	10	9.4	22	25	30
SWBR03-S80	3/8	17.8	10	12.7	26	25	30
SWBR04-S80	1/2	22.2	10	16.1	32	30	33
SWBR06-S80	3/4	27.7	13	21.4	38	30	35
SWBR08-S80	1	34.5	13	27.2	46	40	43
SWBR10-S80	1 1/4	43.2	13	35.5	55	45	46
SWBR12-S80	1 1/2	49.1	13	41.2	63	55	50
SWBR16-S80	2	61.1	16	52.7	75	60	57
6000 lb							
SWBR04-S160	1/2	22.2	13	12.3	35	30	33
SWBR06-S160	3/4	27.7	13	16.2	42	30	35
SWBR08-S160	1	34.5	13	21.2	55	40	43
SWBR10-S160	1 1/4	43.2	13	29.9	60	45	46
SWBR12-S160	1 1/2	49.1	16	34.4	70	55	50
SWBR16-S160	2	61.1	16	43.1	85	60	57

■ 90° Elbow (SLA)

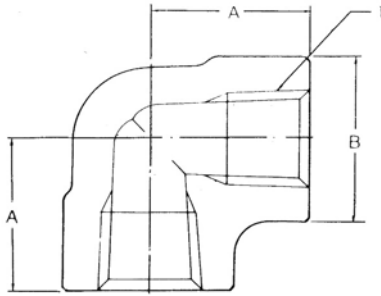

■ 45° Elbow (SLB)

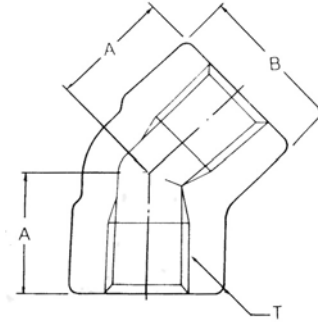

Part No.	Size T	B	A	Unit Weight (kg)
2000 lb				
SLA40-02	¼	23	25.4	0.13
SLA40-03	⅜	26.5	25.4	0.12
SLA40-04	½	34.0	28.5	0.23
SLA40-06	¾	38.5	33.5	0.36
SLA40-08	1	46.5	38.1	0.55
SLA40-10	1¼	56.5	44.5	0.95
SLA40-12	1½	63.5	50.8	1.12
SLA40-16	2	76.0	60.5	1.96
SLA40-20	2½	92.0	76.0	3.25
SLA40-24	3	110.0	86.0	5.64
SLA40-26	3½	121.0	95.5	6.92
SLA40-32	4	146.0	106.5	10.43
3000 lb				
SLA80-02	¼	26.5	25.4	0.120
SLA80-03	⅜	34.0	28.5	0.235
SLA80-04	½	38.5	33.5	0.390
SLA80-06	¾	46.5	38.1	0.570
SLA80-08	1	56.5	44.5	0.990
SLA80-10	1¼	63.5	50.8	1.260
SLA80-12	1½	76.0	60.5	2.125
SLA80-16	2	84.0	64.0	3.520
SLA80-20	2½	110.0	83.0	5.460
SLA80-24	3	121.0	95.5	8.000
SLA80-26	3½	146.0	106.5	11.230
SLA80-32	4	152.0	114.3	13.500
6000 lb				
SLA160-03	⅜	38.5	33.5	0.40
SLA160-04	½	46.5	38.5	0.68
SLA160-06	¾	56.5	44.5	1.13
SLA160-08	1	63.5	50.8	1.59
SLA160-10	1¼	76.0	60.5	2.60
SLA160-12	1½	84.0	64.0	4.32
SLA160-16	2	110.0	85.0	7.33
SLA160-20	2½	121.0	95.5	9.25
SLA160-24	3	146.0	106.5	12.05
SLA160-26	3½	152.0	114.3	14.30
SLA160-32	4	152.0	114.3	14.10

Part No.	Size T	B	A	Unit Weight (kg)
2000 lb				
SLB40-02	¼	23	19.1	0.16
SLB40-03	⅜	26.5	19.1	0.13
SLB40-04	½	34.0	26.0	0.25
SLB40-06	¾	38.5	28.6	0.32
SLB40-08	1	46.5	30.0	0.43
SLB40-10	1¼	56.5	33.3	0.75
SLB40-12	1½	63.5	42.0	1.06
SLB40-16	2	76.0	46.0	1.49
SLB40-20	2½	92.0	53.0	2.45
SLB40-24	3	110.0	64.0	4.00
SLB40-26	3½	121.0	64.0	5.12
SLB40-32	4	146.0	80.0	8.68
3000 lb				
SLB80-02	¼	26.5	19.1	0.16
SLB80-03	⅜	34.0	26.0	0.28
SLB80-04	½	38.5	28.6	0.38
SLB80-06	¾	46.5	30.0	0.51
SLB80-08	1	56.5	33.3	1.03
SLB80-10	1¼	63.5	42.0	1.22
SLB80-12	1½	76.0	46.0	2.36
SLB80-16	2	84.0	53.0	3.66
SLB80-20	2½	110.0	64.0	6.12
SLB80-24	3	121.0	64.0	6.12
SLB80-26	3½	146.0	80.0	8.40
SLB80-32	4	152.0	80.0	11.30
6000 lb				
SLB160-03	⅜	38.5	28.6	0.45
SLB160-04	½	46.5	30.0	0.72
SLB160-06	¾	56.5	33.3	1.00
SLB160-08	1	63.5	42.0	1.56
SLB160-10	1¼	76.0	46.0	2.29
SLB160-12	1½	84.0	53.0	3.80
SLB160-16	2	110.0	64.0	5.76
SLB160-20	2½	121.0	64.0	7.20
SLB160-24	3	146.0	80.0	11.30
SLB160-26	3½	152.0	80.0	13.20
SLB160-32	4	152.0	80.0	11.80

- Dimensions are in millimeters.
- Dimensional Tolerances See ANSI B16.11 or JIS B2316

■ Tee (STA)

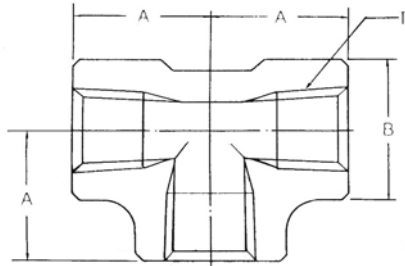

■ Cross (STX)

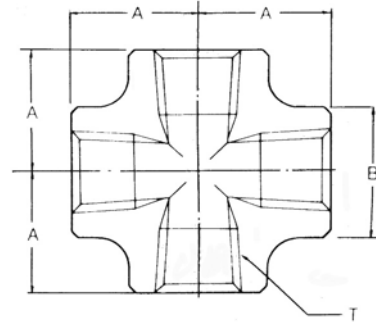

Part No.	Size T	B	A	Unit Weight (kg)
----------	--------	---	---	------------------

2000 lb				
STA40-02	¼	23	25.4	0.18
STA40-03	⅜	26.5	25.4	0.14
STA40-04	½	34.0	28.5	0.26
STA40-06	¾	38.5	33.5	0.43
STA40-08	1	46.5	38.1	0.65
STA40-10	1¼	56.5	44.5	0.91
STA40-12	1½	63.5	50.8	1.25
STA40-16	2	76.0	60.5	2.10
STA40-20	2½	92.0	76.0	3.94
STA40-24	3	110.0	86.0	5.98
STA40-26	3½	121.0	95.5	7.41
STA40-32	4	146.0	106.5	12.36

3000 lb				
STA80-02	¼	26.5	25.4	0.18
STA80-03	⅜	34.0	28.5	0.32
STA80-04	½	38.5	33.5	0.52
STA80-06	¾	46.5	38.1	0.73
STA80-08	1	56.5	44.5	1.26
STA80-10	1¼	63.5	50.8	1.65
STA80-12	1½	76.0	60.5	2.81
STA80-16	2	84.0	64.0	4.35
STA80-20	2½	110.0	83.0	6.26
STA80-24	3	121.0	95.5	10.05
STA80-26	3½	146.0	106.5	14.62
STA80-32	4	152.0	114.3	16.50

6000 lb				
STA160-03	⅜	38.5	33.5	0.59
STA160-04	½	46.5	38.5	0.96
STA160-06	¾	56.5	44.5	1.50
STA160-08	1	63.5	50.8	2.10
STA160-10	1¼	76.0	60.5	3.30
STA160-12	1½	84.0	64.0	5.72
STA160-16	2	110.0	85.0	9.64
STA160-20	2½	121.0	95.5	13.40
STA160-24	3	146.0	106.5	16.15
STA160-26	3½	152.0	114.3	18.23
STA160-32	4	152.0	114.3	16.70

Part No.	Size T	B	A	Unit Weight (kg)
----------	--------	---	---	------------------

2000 lb				
SXA40-02	¼	23	25.4	0.14
SXA40-03	⅜	26.5	25.4	0.22
SXA40-04	½	34.0	28.5	0.37
SXA40-06	¾	38.5	33.5	0.52
SXA40-08	1	46.5	38.1	0.79
SXA40-10	1¼	56.5	44.5	1.28
SXA40-12	1½	63.5	50.8	1.62
SXA40-16	2	76.0	60.5	2.62
SXA40-20	2½	92.0	67.0	4.66
SXA40-24	3	110.0	85.0	7.10
SXA40-26	3½	121.0	95.5	8.85
SXA40-32	4	146.0	106.5	14.83

3000 lb				
SXA80-02	¼	26.5	25.4	0.23
SXA80-03	⅜	34.0	28.5	0.40
SXA80-04	½	28.5	33.5	0.63
SXA80-06	¾	46.5	38.1	0.93
SXA80-08	1	56.5	44.5	1.47
SXA80-10	1¼	63.5	50.8	1.78
SXA80-12	1½	76.0	60.5	3.42
SXA80-16	2	92.0	67.0	5.50
SXA80-20	2½	110.0	85.0	7.66
SXA80-24	3	121.0	95.5	11.21
SXA80-26	3½	146.0	106.5	16.72
SXA80-32	4	152.0	114.3	19.00

6000 lb				
SXA160-03	⅜	38.5	33.5	0.67
SXA160-04	½	46.5	38.1	1.12
SXA160-06	¾	56.5	44.5	1.90
SXA160-08	1	63.5	50.8	2.90
SXA160-10	1¼	76.0	60.5	4.20
SXA160-12	1½	92.0	67.0	6.65
SXA160-16	2	110.0	85.0	10.00
SXA160-20	2½	121.0	95.5	16.00
SXA160-24	3	146.0	106.5	19.87
SXA160-26	3½	152.0	114.3	28.10
SXA160-32	4	152.0	114.3	24.60

- Dimensions are in millimeters.
- Dimensional Tolerances See ANSI B16.11 or JIS B2316

■ Full Coupling (SFC)

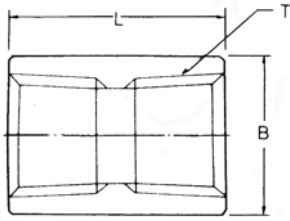

■ Half Coupling (SHC)

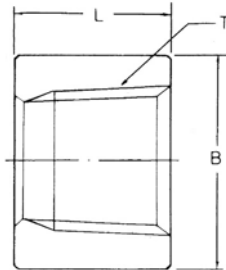

■ CAP (SCA)

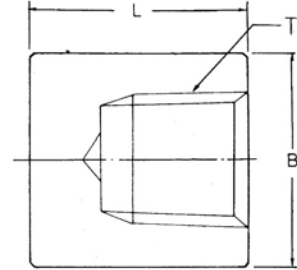

Part No.	Size T	B	L	Unit Weight (kg)
----------	--------	---	---	------------------

3000 lb

SFC80-02	¼	22.0	35.1	0.050
SFC80-03	⅜	25.0	38.1	0.061
SFC80-04	½	30.0	48.0	0.142
SFC80-06	¾	35.0	51.0	0.218
SFC80-08	1	45.0	61.0	0.418
SFC80-10	1¼	57.0	67.0	0.720
SFC80-12	1½	63.5	80.0	1.065
SFC80-16	2	76.0	86.0	1.400
SFC80-20	2½	92.0	92.0	2.550
SFC80-24	3	108.0	108.0	3.830
SFC80-26	3½	127.0	114.3	5.720
SFC80-32	4	140.0	121.0	6.350

6000 lb

SFC160-02	¼	25.0	35.0	0.120
SFC160-03	⅜	32.0	38.0	0.180
SFC160-04	½	38.1	48.0	0.280
SFC160-06	¾	45.0	51.0	0.450
SFC160-08	1	57.0	61.0	0.800
SFC160-10	1¼	63.5	67.0	1.400
SFC160-12	1½	76.0	80.0	1.950
SFC160-16	2	92.0	86.0	2.800
SFC160-20	2½	108.0	92.0	3.800
SFC160-24	3	127.0	108.0	6.010
SFC160-26	3½	140.0	114.3	8.250
SFC160-32	4	160.0	121.0	10.700

Part No.	Size T	B	L	Unit Weight (kg)
----------	--------	---	---	------------------

3000 lb

SHC80-02	¼	22.0	17.5	0.025
SHC80-03	⅜	25.0	19.0	0.030
SHC80-04	½	30.0	24.0	0.070
SHC80-06	¾	35.0	25.5	0.100
SHC80-08	1	45.0	30.5	0.210
SHC80-10	1¼	57.0	33.5	0.365
SHC80-12	1½	63.5	40.0	0.520
SHC80-16	2	76.0	43.0	0.690
SHC80-20	2½	92.0	46.0	1.250
SHC80-24	3	108.0	54.0	1.840
SHC80-26	3½	127.0	57.5	2.860
SHC80-32	4	140.0	60.5	3.510

6000 lb

SHC160-02	¼	25.0	17.5	0.06
SHC160-03	⅜	32.0	19.0	0.09
SHC160-04	½	38.1	24.0	0.14
SHC160-06	¾	45.0	25.5	0.23
SHC160-08	1	57.0	30.5	0.37
SHC160-10	1¼	63.5	33.5	0.70
SHC160-12	1½	76.0	40.0	0.90
SHC160-16	2	92.0	43.0	1.22
SHC160-20	2½	108.0	46.0	1.85
SHC160-24	3	127.0	54.0	2.95
SHC160-26	3½	140.0	57.5	4.12
SHC160-32	4	160.0	60.5	5.40

Part No.	Size T	B	L	Unit Weight (kg)
----------	--------	---	---	------------------

3000 lb

SCA80-02	¼	22.0	25	0.05
SCA80-03	⅜	25.0	25	0.08
SCA80-04	½	30.0	32	0.12
SCA80-06	¾	35.0	37	0.20
SCA80-08	1	45.0	41	0.31
SCA80-10	1¼	57.0	44	0.60
SCA80-12	1½	63.5	44	0.73
SCA80-16	2	76.0	48	1.05
SCA80-20	2½	92.0	60	2.27
SCA80-24	3	108.0	65	3.83
SCA80-26	3½	127.0	68	4.52
SCA80-32	4	140.0	68	6.35

6000 lb

SCA160-02	¼	25.0	27	0.09
SCA160-03	⅜	32.0	27	0.14
SCA160-04	½	38.1	33	0.25
SCA160-06	¾	45.0	38	0.36
SCA160-08	1	57.0	43	0.70
SCA160-10	1¼	63.5	46	0.80
SCA160-12	1½	76.0	48	1.28
SCA160-16	2	92.0	51	2.16
SCA160-20	2½	108.0	64	2.72
SCA160-24	3	127.0	68	4.95
SCA160-26	3½	140.0	70	6.84
SCA160-32	4	160.0	75	9.21

- Dimensions are in millimeters.
- Dimensional Tolerances See ANSI B16.11 or JIS B2316

■ Hex Head Pulg (SPB)

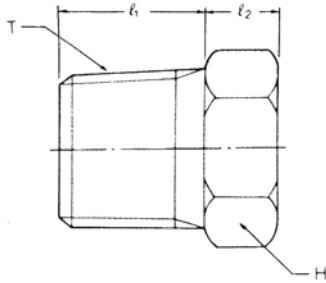

Part No.	Size T	1	2	H	Unit Weight (kg)
----------	--------	---	---	---	------------------

3000 lb

SPB-01	1/8	11	6.3	11.0	0.03
SPB-02	1/4	13	6.3	14.0	0.03
SPB-03	3/8	14	8.0	19.0	0.06
SPB-04	1/2	18	8.0	22.0	0.08
SPB-06	3/4	19	10.0	27.0	0.14
SPB-08	1	21	10.0	35.0	0.22
SPB-10	1 1/4	22	14.0	46.0	0.51
SPB-12	1 1/2	24	16.0	50.0	0.62
SPB-16	2	25	18.0	63.5	1.02
SPB-20	2 1/2	32	19.0	76.2	1.76
SPB-24	3	40	21.0	99.0	2.66
SPB-26	3 1/2	41	22.0	103.0	3.72
SPB-32	4	42	32.0	117.0	5.90

■ Square Pulg (SPD)

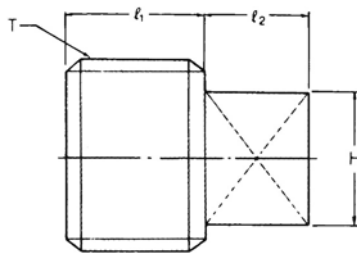

Part No.	Size T	1	2	H	Unit Weight (kg)
----------	--------	---	---	---	------------------

3000 lb

SPD-01	1/8	9.9	6.6	7.0	0.007
SPD-02	1/4	13.0	6.6	9.0	0.014
SPD-03	3/8	13.0	7.9	12.0	0.028
SPD-04	1/2	15.0	9.9	14.0	0.057
SPD-06	3/4	16.0	11.0	17.0	0.085
SPD-08	1	20.1	13.0	19.0	0.140
SPD-10	1 1/4	21.1	15.0	24.0	0.255
SPD-12	1 1/2	21.1	16.0	27.0	0.397
SPD-16	2	23.1	18.0	32.0	0.680
SPD-20	2 1/2	27.0	20.0	38.1	1.020
SPD-24	3	29.0	21.0	42.9	1.301
SPD-26	3 1/2	30.0	22.2	47.6	2.050
SPD-32	4	32.0	25.0	63.5	3.257

■ Round Plug (SPE)

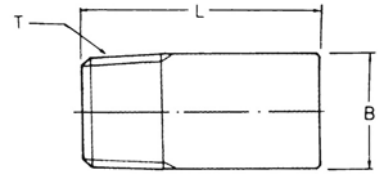

Part No.	Size T	B	L	Unit Weight (kg)
----------	--------	---	---	------------------

3000 lb

SPE-01	1/8	10.3	35.0	0.057
SPE-02	1/4	13.5	41.3	0.057
SPE-03	3/8	17.5	41.3	0.085
SPE-04	1/2	21.4	44.5	0.170
SPE-06	3/4	27.0	44.5	0.170
SPE-08	1	33.4	50.8	0.340
SPE-10	1 1/4	42.9	50.8	0.340
SPE-12	1 1/2	48.4	50.8	0.710
SPE-16	2	60.3	63.5	1.361
SPE-20	2 1/2	73.0	70.0	2.155
SPE-24	3	88.9	70.0	3.456
SPE-26	3 1/2	101.6	76.2	4.216
SPE-32	4	114.3	76.2	5.838

■ Reducing Coupling (SRC)

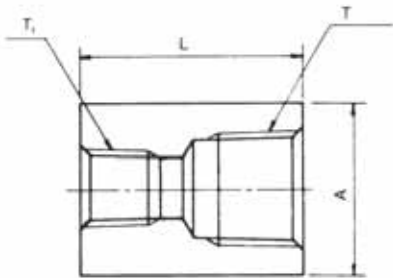

Part No.	T (PT) × T1 (PT)	A	L
SRC02-01R	1/4 × 1/8	22	35.1
SRC03-02R	3/8 × 1/4	25	38.1
SRC04-02R	1/2 × 1/4	30	47.8
SRC04-03R	1/2 × 3/8	30	47.8
SRC06-02R	3/4 × 1/4	35	50.8
SRC06-03R	3/4 × 3/8	35	50.8
SRC06-04R	3/4 × 1/2	35	50.8
SRC08-03R	1 × 3/8	45	60.5
SRC08-04R	1 × 1/2	45	60.5
SRC08-06R	1 × 3/4	45	60.5
SRC10-04R	1 1/4 × 1/2	60	66.5
SRC10-06R	1 1/4 × 3/4	60	66.5
SRC10-08R	1 1/4 × 1	60	66.5
SRC12-06R	1 1/2 × 3/4	65	79.3
SRC12-08R	1 1/2 × 1	65	79.3
SRC12-10R	1 1/2 × 1 1/4	65	79.3
SRC16-08R	2 × 1	80	85.9
SRC16-10R	2 × 1 1/4	80	85.9

■ Hex Nipple (SNA)

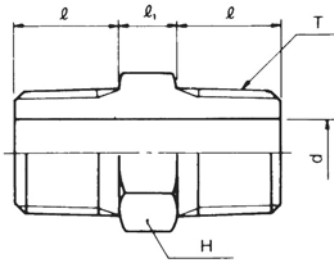

Part No.	T (PT)	d	H		1
SNA-01R	1/8	4	HEX 12	10	6
SNA-02R	1/4	7	HEX 17	14	8
SNA-03R	3/8	9	HEX 19	15	8
SNA-04R	1/2	12	HEX 22	19	9
SNA-06R	3/4	16	HEX 27	21	10
SNA-08R	1	20	HEX 36	24	11
SNA-10R	1 1/4	28	HEX 46	27	12
SNA-12R	1 1/2	32	HEX 50	27	14
SNA-16R	2	40	HEX 65	31	16

■ Reducing Nipple (SNR)

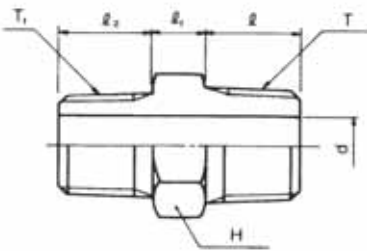

Part No.	T (PT) × T ₁ (PT)	d	H		1	L
SNR02-01R	1/4 × 1/8	4	HEX 17	14	8	10
SNR03-02R	3/8 × 1/4	7	HEX 19	15	8	14
SNR04-02R	1/2 × 1/4	7	HEX 22	19	9	14
SNR04-03R	1/2 × 3/8	9	HEX 22	19	9	15
SNR06-02R	3/4 × 1/4	7	HEX 27	21	10	14
SNR06-03R	3/4 × 3/8	9	HEX 27	21	10	15
SNR06-04R	3/4 × 1/2	12	HEX 27	21	10	19
SNR08-03R	1 × 3/8	9	HEX 36	24	11	15
SNR08-04R	1 × 1/2	12	HEX 36	24	11	19
SNR08-06R	1 × 3/4	16	HEX 36	24	11	21
SNR10-04R	1 1/4 × 1/2	12	HEX 46	27	12	19
SNR10-06R	1 1/4 × 3/4	16	HEX 46	27	12	21
SNR10-08R	1 1/4 × 1	20	HEX 46	27	12	24
SNR12-06R	1 1/2 × 3/4	16	HEX 50	27	14	21
SNR12-08R	1 1/2 × 1	20	HEX 50	27	14	24
SNR12-10R	1 1/2 × 1 1/4	28	HEX 50	27	14	27
SNR16-08R	2 × 1	20	HEX 65	31	16	24
SNR16-10R	2 × 1 1/4	28	HEX 65	31	16	27
SNR16-12R	2 × 1 1/2	32	HEX 65	31	16	27

■ Hex Socket (SSA)

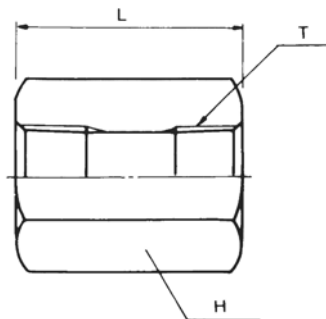

Part No.	T (PT)	H	L
SSA-01R	1/8	HEX 19	30
SSA-02R	1/4	HEX 22	30
SSA-03R	3/8	HEX 24	30
SSA-04R	1/2	HEX 32	40
SSA-06R	3/4	HEX 36	42
SSA-08R	1	HEX 46	50
SSA-10R	1 1/4	HEX 55	55
SSA-12R	1 1/2	HEX 65	55
SSA-16R	2	HEX 75	64

■ Hex Bushing (SHB)

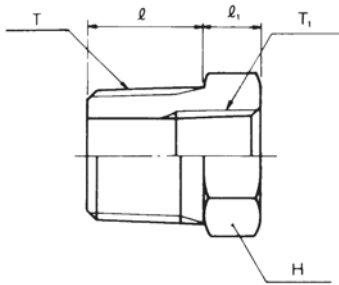

Part No.	T (PT) × T ₁ (PT)	H		1
SHB02-01R	¼ × ⅛	HEX 17	14	8
SHB03-02R	⅜ × ¼	HEX 19	15	8
SHB04-02R	½ × ¼	HEX 24	19	9
SHB04-03R	½ × ⅜	HEX 24	19	9
SHB06-02R	¾ × ¼	HEX 30	21	10
SHB06-03R	¾ × ⅜	HEX 30	21	10
SHB06-04R	¾ × ½	HEX 30	21	10
SHB08-02R	1 × ¼	HEX 36	24	11
SHB08-03R	1 × ⅜	HEX 36	24	11
SHB08-04R	1 × ½	HEX 36	24	11
SHB08-06R	1 × ¾	HEX 36	24	11
SHB10-04R	1 ¼ × ½	HEX 46	27	12
SHB10-06R	1 ¼ × ¾	HEX 46	27	12
SHB10-08R	1 ¼ × 1	HEX 46	27	12
SHB12-04R	1 ½ × ½	HEX 50	27	14
SHB12-06R	1 ½ × ¾	HEX 50	27	14
SHB12-08R	1 ½ × 1	HEX 50	27	14
SHB12-10R	1 ½ × 1 ¼	HEX 50	27	14
SHB16-06R	2 × ¾	HEX 65	31	16
SHB16-08R	2 × 1	HEX 65	31	16
SHB16-10R	2 × 1 ¼	HEX 65	31	16
SHB16-12R	2 × 1 ½	HEX 65	31	16

■ Boss Type A (SBA)

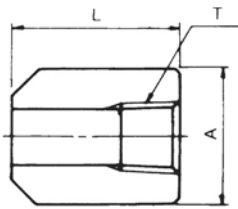

Part No.	T (PT)	A	L
SBA-02R	¼	22	30
SBA-03R	⅜	26	30
SBA-04R	½	32	33
SBA-06R	¾	38	35
SBA-08R	1	46	43
SBA-10R	1 ¼	55	46
SBA-12R	1 ½	65	50
SBA-16R	2	75	57

■ Boss Type R (SBR)

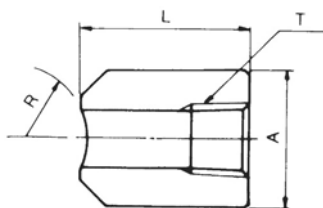

Part No.	T (PT)	A	L	R
SBR-02R	¼	22	30	25
SBR-03R	⅜	26	30	25
SBR-04R	½	32	33	30
SBR-06R	¾	38	35	30
SBR-08R	1	46	43	40
SBR-10R	1 ¼	55	46	45
SBR-12R	1 ½	65	50	55
SBR-16R	2	75	57	60

■ R.J Union (SUA)

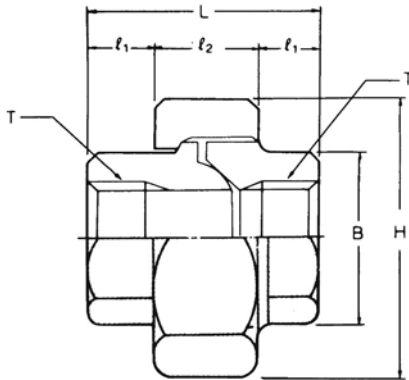

Part No.	Size T	B	1	2	L	H	Unit Weight (kg)
3000 lb							
SUA80-02	¼	21.0	11.5	18	41	35 HEX	0.19
SUA80-03	⅜	25.0	14.0	18	46	40 HEX	0.25
SUA80-04	½	32.0	15.0	21	51	46 HEX	0.43
SUA80-06	¾	40.0	17.0	23	57	58 HEX	0.62
SUA80-08	1	48.0	19.5	25	64	65 HEX	1.03
SUA80-10	1 ¼	55.5	22.5	27	72	76 OCT	1.15
SUA80-12	1 ½	63.5	24.0	30	78	83 OCT	1.54
SUA80-16	2	76.0	26.0	36	88	103 OCT	3.05
SUA80-20	2 ½	95.0	34.0	42	110	124 OCT	5.14
SUA80-24	3	116.0	37.0	45	120	150 OCT	7.12
SUA80-32	4	148.0	45.0	50	140	180 OCT	12.40
6000 lb							
SUA160-02	¼	25.4	13.5	19	46	40 HEX	0.25
SUA160-03	⅜	32.0	15.0	21	51	46 HEX	0.43
SUA160-04	½	40.0	17.0	23	57	56 HEX	0.62
SUA160-06	¾	44.5	19.5	25	64	65 HEX	0.94
SUA160-08	1	51.0	22.5	27	72	74 OCT	1.08
SUA160-10	1 ¼	57.2	24.0	30	78	83 OCT	1.41
SUA160-12	1 ½	71.5	26.0	36	88	103 OCT	2.75
SUA160-16	2	90.0	34.0	42	110	124 OCT	5.05
SUA160-20	2 ½	105.0	37.5	45	120	150 OCT	6.87
SUA160-24	3	125.0	45.0	50	140	180 OCT	10.85

■ O-Ring Union (SUAO)

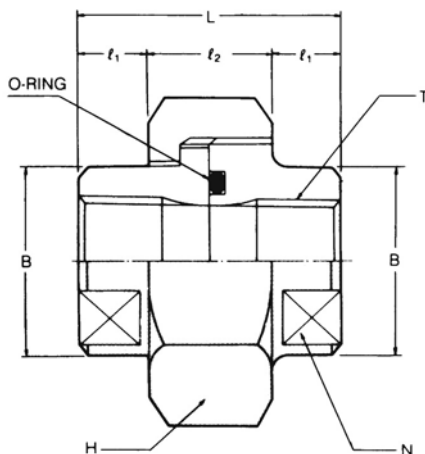

Part No.	Size T	B	1	L	N	H	O-Ring	Unit Weight (kg)	
3000 lb									
SUAO80-02	¼	22	10	18	38	21	35 HEX	P18	0.160
SUAO80-03	⅜	27	10	18	38	26	41 HEX	P20	0.215
SUAO80-04	½	32	12	20	44	32	46 HEX	G25	0.312
SUAO80-06	¾	38	12	26	50	38	54 HEX	G30	0.477
SUAO80-08	1	47	15	26	56	46	63 HEX	G35	0.764
SUAO80-10	1 ¼	56	15	30	60	54	77 HEX	G45	1.106
SUAO80-12	1 ½	63	18	36	72	63	80 OCT	G50	1.327
SUAO80-16	2	76	18	36	72	77	95 OCT	G65	1.856

- Dimensions are in millimeters.
- Dimensional Tolerances See ANSI B16.11 or JIS B2316

Weldolet (SWLT)

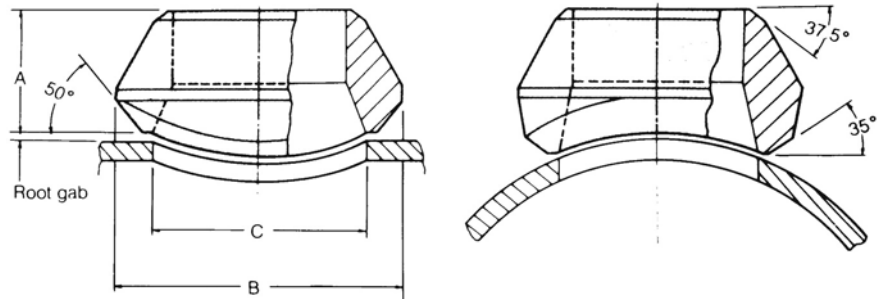

STD, X-S

Outlet Size	A		B		C		APP'Weight(kg)	
	STD	X-S	STD	X-S	STD	X-S	STD	X-S
1/2	19.1	19.1	34.9	34.9	23.8	23.8	0.08	0.09
3/4	22.2	22.2	44.5	44.5	30.2	30.2	0.11	0.14
1	27.0	27.0	54.0	54.0	36.5	36.5	0.23	0.21
1 1/4	31.8	31.8	65.1	65.1	44.5	44.5	0.36	0.41
1 1/2	33.3	33.3	73.0	73.0	50.8	50.8	0.45	0.50
2	38.1	38.1	88.9	88.9	65.1	65.1	0.80	0.80
2 1/2	41.3	41.3	103.2	103.2	76.2	76.2	1.14	1.20
3	44.5	44.5	122.2	122.2	93.7	93.7	1.82	1.90
4	50.8	50.8	152.4	152.4	120.7	120.7	2.86	2.90
5	57.2	57.2	179.4	179.4	141.3	141.3	4.66	4.70
6	60.3	77.8	215.9	225.4	169.9	169.9	6.45	10.50
8	69.9	98.5	263.5	292.1	220.7	220.7	10.68	16.80
10	77.8	93.7	322.3	323.9	274.7	265.1	17.73	20.90
12	85.7	103.2	377.8	397.4	325.4	317.5	26.82	27.70
14	88.9	100.0	409.6	431.8	357.2	350.8	30.00	31.80
16	93.7	106.4	463.6	466.7	408.0	403.2	34.10	46.40
18	96.8	111.1	520.7	523.9	458.8	455.6	44.10	59.10
20	101.6	119.1	571.5	582.6	508.0	509.6	53.60	71.80
24	115.9	139.7	689.0	708.0	614.4	638.2	100.00	131.80

Sch 160, XX-S

Outlet Size	A		B		C		APP'Weight(kg)	
	Sch 160	XX-s	Sch 160	XX-s	Sch 160	XX-s	Sch 160	XX-s
1/2	28.6	28.6	34.9	34.9	14.3	14.3	0.11	-
3/4	31.8	31.8	44.5	44.5	19.1	19.1	0.32	-
1	38.1	38.1	50.8	50.8	25.4	25.4	0.38	0.38
1 1/4	44.5	44.5	61.9	61.9	33.3	33.3	0.57	0.57
1 1/2	50.8	50.8	69.9	69.9	38.1	38.1	0.80	0.80
2	55.6	55.6	81.0	81.0	42.9	42.9	1.00	1.00
2 1/2	61.9	61.9	96.8	96.8	54.0	54.0	1.54	1.54
3	73.0	73.0	120.7	120.7	73.0	73.0	2.90	2.90
4	84.1	84.1	152.4	152.4	98.4	98.4	4.80	4.80
5	93.7	93.7	187.3	187.3	122.2	122.2	6.50	6.50
6	104.8	104.8	220.7	220.7	146.1	146.1	12.70	12.70
8	111.1	111.1	284.2	284.2	173.0	173.0	20.50	20.50
10	125.4	125.4	312.7	312.7	215.9	215.9	38.60	38.60

- Dimensions are in millimeters.
- Applicable Run Pipe Sizes are from Out-Let size to 36 inch.

■ Sockolet (SCLT)

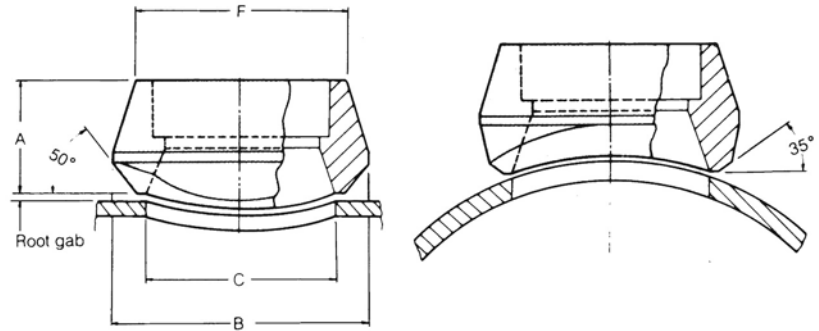

Outlet Size	A		B		C		F		APP'Weight(kg)	
	3000#	6000#	3000#	6000#	3000#	6000#	3000#	6000#	3000#	6000#
½	25.4	31.8	34.9	44.5	23.8	19.1	31.8	39.7	0.14	0.23
¾	27.0	36.5	44.5	50.8	30.2	25.4	36.5	46.6	0.15	0.36
1	33.3	39.7	54.0	61.9	36.5	33.3	46.0	57.2	0.27	0.59
1¼	33.3	41.3	65.1	69.9	44.5	38.1	55.6	65.1	0.39	0.73
1½	34.9	42.9	73.0	82.6	50.8	49.2	61.9	76.2	0.47	0.91
2	38.1	58.7	88.9	103.2	65.1	58.7	74.6	92.1	0.73	2.33
2½	46.0	-	103.2	-	76.2	-	87.3	-	1.25	-
3	50.8	-	122.2	-	93.7	-	104.8	-	1.73	-
4	57.2	-	152.4	-	120.7	-	130.2	-	3.30	-

■ Thredolet (STLT)

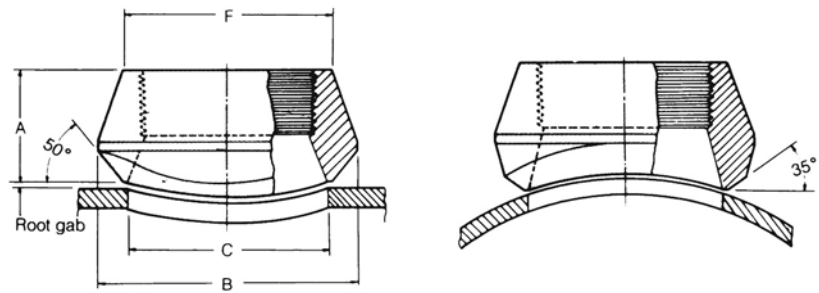

Outlet Size	A		B		C		F		APP'Weight(kg)	
	3000#	6000#	3000#	6000#	3000#	6000#	3000#	6000#	3000#	6000#
½	25.4	31.8	34.9	44.5	23.8	19.1	31.8	39.7	0.11	0.20
¾	27.0	36.5	44.5	50.8	30.2	25.4	36.5	46.6	0.16	0.34
1	33.3	39.7	54.0	61.9	36.5	33.3	46.0	57.2	0.28	0.56
1¼	33.3	41.3	65.1	69.9	44.5	38.1	55.6	65.1	0.41	0.71
1½	34.9	42.9	73.0	82.6	50.8	49.2	61.9	76.2	0.45	0.89
2	38.1	52.4	88.9	103.2	65.1	69.9	74.6	92.1	0.80	2.31
2½	46.0	-	103.2	-	76.2	-	87.3	-	1.36	-
3	50.8	-	122.2	-	93.7	-	104.8	-	1.98	-
4	57.2	-	152.4	-	120.7	-	130.2	-	3.23	-

- Dimensions are in millimeters.
- Applicable Run Pipe Sizes are from Out-let Size to 36 inch
- For the 3000# and 6000# Sockolets and Thredolets, Inside Bore, Thread Socket Bore and Socket Depth Dimensions are According to ANSI B16.11.

■ Nippolet

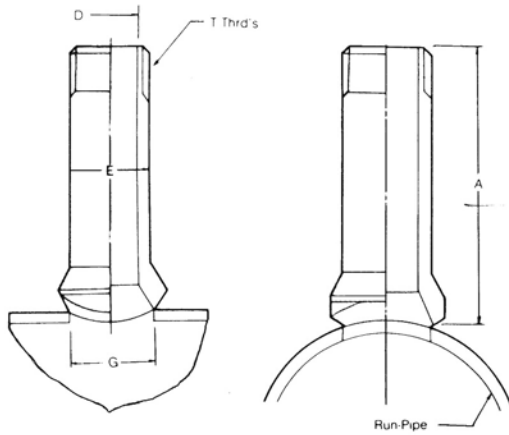

Run Pipe Size	Outlet Size T	A	G	D	E	Unit Weight (kg)
36- 3/4	1/2	88.9	23.9	14.0	21.3	0.36
36-1	3/4	88.9	30.2	18.8	26.7	0.56
36-1 1/4	1	88.9	36.6	24.4	33.3	0.84
36-1 1/2	1 1/4	88.9	44.5	32.5	42.2	1.22
36-2	1 1/2	88.9	50.8	38.1	48.3	2.00
36-2 1/2	2	88.9	65.0	49.3	60.5	3.12

■ Swaged Nipple

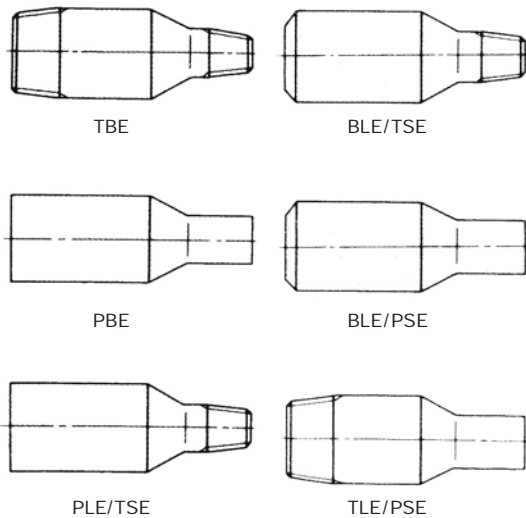

Large end Size	Small end Size	Length(mm)
1/2	3/8 - 1/8	70
3/4	1/2 - 1/8	76
1	3/4 - 1/8	89
1 1/4	1 - 1/8	102
1 1/2	1 1/4 - 1/8	114
2	1 1/2 - 1/8	165
2 1/2	2 - 1/8	178
3	2 1/2 - 1/8	203
3 1/2	3 - 1/8	203
4	3 1/2 - 1/8	229

TBE: Threaded both end
 PBE: Plain both end
 PLE/TSE: Plain large end-Threaded small end
 BLE/TSE: Beveled large end-Threaded small end
 BLE/PSE: Beveled large end-Plain small end
 TLE/PSE: Threaded large end-Plain small-end

• Swaged Nipples are made from Forged Steel or Pipe

1. Forged Socket Welding. Threaded Fitting Bore

in millimeters.

	ANSI B16.11		JIS B2316	
	Socket Welding(M)	Threaded(T)	Socket Welding(M)	Threaded(T)
1/8"	10.90, 10.65	NPT 1/8	11.0	PT 1/8
1/4"	14.35, 14.10	NPT 1/4	14.3	PT 1/4
3/8"	17.80, 17.55	NPT 3/8	17.8	PT 3/8
1/2"	21.95, 21.70	NPT 1/2	22.2	PT 1/2
3/4"	27.30, 27.05	NPT 3/4	27.7	PT 3/4
1"	34.05, 33.80	NPT 1	34.5	PT 1
1 1/4"	42.80, 42.55	NPT 1 1/4	43.2	PT 1 1/4
1 1/2"	48.90, 48.65	NPT 1 1/2	49.1	PT 1 1/2
2"	61.35, 61.10	NPT 2	61.1	PT 2
2 1/2"	74.20, 73.80	NPT 2 1/2	77.1	PT 2 1/2
3"	90.15, 89.80	NPT 3	90.0	PT 3
4"	115.8, 115.45	NPT 4	115.4	PT 4

2. TOLERANCE

Forged Socket Welding, Threaded Fitting (ANSI B16.11)

Nominal Pipe Size	All Fittings				Elbow, Tee, Cross	Coupling	Half Coupling
	Socket Bore Dia	Bore Dia. of Fitting	Concentricity of Bore	Concidence of Axis	Center to Bottom of Socket	Bottom to Bottom of Socket	Bottom of Socket to Opposite Face
1/8-1/4	+0.012 -0.000	±0.03	Socket and Fitting bores within ±0.03	Maximum variation in alignment of socket and fitting bores for 1/8 in 12	±0.03	±0.06	±0.03
3/8-3/4	+0.012 -0.000	±0.03			±0.06	±0.12	±0.06
1-2	+0.012 -0.000	±0.03			±0.08	±0.16	±0.08
2 1/2-3	+0.012 -0.000	±0.06			±0.10	±0.20	±0.10

3. KS B0222 & JIS B0203 Pipe Threads

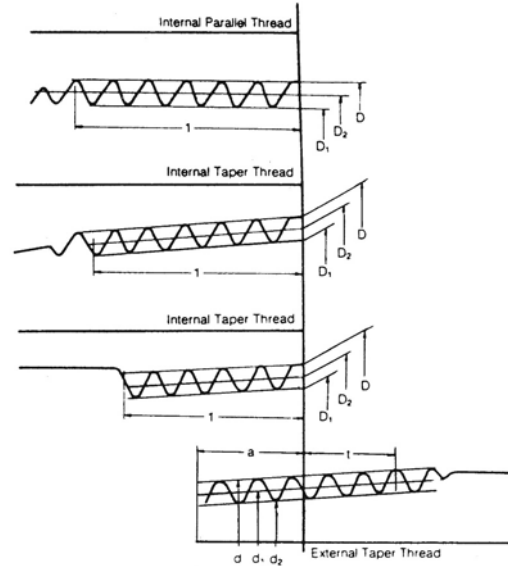

Basic Thread Data

Nominal Size	Number of Threads Per Inch	Screw Thread			Basic Diameter			Position of Basic Diameter			Tolerances on Basic Diameters of Internal Parallel Thread	Effective Thread Length (Min.)			Nominal Pipe Size (For Reference)		
		Pitch	Height of Thread	Rounding	External Thread			External Thread	Internal Thread	Fitting Allowance		Internal Thread					
					Major Diameter d	Pitch Diameter d_2	Minor Diameter d_1	From the End of Pipe	The End of Pipe			When there is an Incomplete thread or More	When There is on Incomplete Thread				
		Internal Thread			Basic Length	Tolerance Axially	Tolerance Axially	Outside Diameter	Wall thickness								
		Major Diameter	Pitch Diameter	Minor Diameter													
n	p	h	r	D	D_2	D_1	a	$\pm b$	$\pm C$	\pm	f	l	l	t			
PT 15($\frac{1}{2}$)	14	1.8143	1.162	0.25	20.955	19.793	18.631	8.16	1.81	2.27	0.142	5.00	12.7	15.0	9.1	21.7	2.8
PT 20($\frac{3}{4}$)	14	1.8143	1.162	0.25	26.441	25.279	24.117	9.53	1.81	2.27	0.142	5.60	14.1	16.3	10.2	27.2	2.8
PT 25(1)	11	2.3091	1.479	0.32	33.249	31.770	30.291	10.39	2.31	2.89	0.180	6.40	16.2	19.0	11.5	34.0	3.2
PT 32($1\frac{1}{4}$)	11	2.3091	1.479	0.32	41.910	40.431	38.952	12.70	2.31	2.89	0.180	6.40	18.5	21.4	13.4	42.7	3.5
PT 40($1\frac{1}{2}$)	11	2.3091	1.479	0.32	47.803	46.324	44.845	12.70	2.31	2.89	0.180	6.40	18.5	21.4	13.4	48.6	3.5
PT 50(2)	11	2.3091	1.479	0.32	59.614	58.135	56.656	15.88	2.31	2.89	0.180	7.50	22.8	25.7	16.9	60.5	3.8
PT 65($2\frac{1}{2}$)	11	2.3091	1.479	0.32	75.184	73.705	72.226	17.46	3.64	3.46	0.217	9.22	26.7	30.2	18.6	76.3	4.2
PT 80(3)	11	2.3091	1.479	0.32	87.884	86.405	84.926	20.64	3.64	3.46	0.217	9.22	29.9	33.3	21.1	89.1	4.2
PT 90($3\frac{1}{2}$)	11	2.3091	1.479	0.32	100.330	98.851	97.372	22.23	3.64	3.46	0.217	9.30	31.5	34.9	22.4	101.6	4.2
PT100(4)	11	2.3091	1.479	0.32	113.030	111.551	110.072	25.40	3.64	3.46	0.217	10.40	35.9	39.3	25.9	114.3	4.5
PT125(5)	11	2.3091	1.479	0.32	138.430	136.952	135.472	25.58	3.64	3.46	0.217	11.40	40.1	43.6	29.3	139.8	4.5
PT150(6)	11	2.3091	1.479	0.32	163.830	162.351	160.872	28.58	3.64	3.46	0.217	11.50	40.1	43.6	29.3	165.2	5.0

• Dimensions are in millimeters.

4. ANSI B2.1 Taper Pipe Threads. (Except Dryseal)

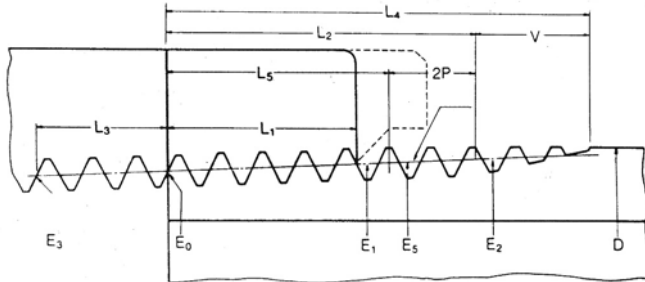

Taper 1 in 16 on Diameter
(Shown Exaggerated in Diagram)

Thread Height Dimensions

Thread Element	27 Threads Per inch $p=0.03704$	18 Threads Per inch $p=0.05556$	14 Threads Per inch $p=0.07143$	11½ Threads Per inch $p=0.08696$	8 Threads Per inch $p=0.12500$
$H=0.866p$	0.0321	0.4810	0.0619	0.0753	0.1082
$hs=hh=0.760p$	0.0281	0.0422	0.0543	0.0661	0.0950
$frs=frn=0.033p$	0.0012	0.0088	0.0024	0.0029	0.0041
$fcs=fcn=0.073p$	0.0027	0.0041	0.0052	0.0063	0.0091

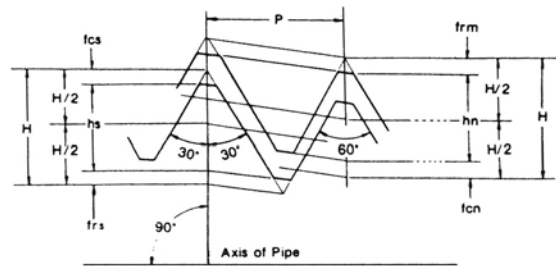

Basic Thread Data

Nominal Pipe Size (NPT)	Outside Diameter of Pipe D	Threads Per inch n	Pitch of Thread P	Pitch Diameter at beginning of External Thread	Handtight Engagement			Effective Thread, External		
					Length L_1		Dia E_1	Length L_2		Dia E_2
					In.	Thds.		In.	Thds.	
1	2	3	4	5	6	7	8	9	10	11
1/8	0.405	27.0	0.03704	0.36351	0.1615	4.36	0.37360	0.2639	7.12	0.38000
1/4	0.540	18.0	0.05556	0.47739	0.2278	4.10	0.49163	0.4018	7.23	0.50250
3/8	0.675	18.0	0.05556	0.61201	0.2400	4.32	0.62701	0.4078	7.43	0.63750
1/2	0.840	14.0	0.07143	0.75843	0.3200	4.48	0.77843	0.5337	7.47	0.79179
3/4	1.050	14.0	0.07143	0.96768	0.3390	4.75	0.98887	0.5457	7.64	1.00179
1	1.315	11.5	0.08696	1.21363	0.4000	4.60	1.23863	0.6828	7.85	1.25630
1 1/4	1.660	11.5	0.08696	1.55713	0.4200	4.83	1.58338	0.7068	8.13	1.60130
1 1/2	1.900	11.5	0.08696	1.79609	0.4200	4.83	1.82234	0.7235	8.32	1.84130
2	2.375	11.5	0.08696	2.26902	0.4360	5.01	2.29627	0.7565	8.70	2.31630
2 1/2	2.875	8.0	0.12500	2.71953	0.6820	5.46	2.76216	1.1375	9.10	2.79062
3	3.500	8.0	0.12500	3.34062	0.7660	6.13	3.38850	1.2000	9.60	3.41562
3 1/2	4.000	8.0	0.12500	3.83750	0.8210	6.57	3.88881	1.2500	10.00	3.91562
4	4.500	8.0	0.12500	4.33438	0.8440	6.75	4.38712	1.3000	10.40	4.41562

Nominal Pipe Size (NPT)	Wrench Makeup Length for External Thread $L_2 L_1$		Wrench Makeup Length for External Thread			Vanish Thread V		Overall Length External Thread L_4	Nominal, Complet External Threads ¹		Height of Thread h	Increase in Dia per Thread, 0.0625/n	Basic Minor Dia at Small End of Pipe, Ka
	In.	Thds.	In.	Thds.	Dia E_3	In.	Thds.		Length L_5	Dia L_5			
1	12	13	14	15	16	17	18	19	20	21	22	23	24
1/8	0.1024	2.76	0.1111	3	0.35656	0.1285	3.47	0.3924	0.1898	0.37537	0.02963	0.00231	0.3339
1/4	0.1740	3.13	0.1667	3	0.46697	0.1928	3.47	0.5946	0.2907	0.49556	0.04444	0.00347	0.4329
3/8	0.1678	3.02	0.1667	3	0.60160	0.1928	3.47	0.6006	0.2967	0.63056	0.04444	0.00347	0.5676
1/2	0.2137	2.99	0.2143	3	0.74504	0.2478	3.47	0.7815	0.3909	0.78286	0.05714	0.00446	0.7013
3/4	0.2067	2.89	0.2143	3	0.95429	0.2478	3.47	0.7935	0.4029	0.99286	0.05714	0.00446	0.9105
1	0.2828	3.25	0.2609	3	1.19733	0.3017	3.47	0.9845	0.5089	1.24543	0.06957	0.00543	1.1441
1 1/4	0.2868	3.30	0.2609	3	1.54083	0.3017	3.47	1.0085	0.5329	1.59043	0.06957	0.00543	1.4876
1 1/2	0.3035	3.49	0.2609	3	1.77978	0.3017	3.47	1.0252	0.5496	1.83043	0.06957	0.00543	1.7265
2	0.3205	3.69	0.2609	3	2.25272	0.3017	3.47	1.0582	0.5826	2.30543	0.06957	0.00543	2.1995
2 1/2	0.4555	3.64	0.2500	2	2.70391	0.4337	3.47	1.5712	0.8875	2.77500	0.10000	0.00781	2.6195
3	0.4340	3.47	0.2500	2	3.32500	0.4337	3.47	1.6337	0.9500	3.40000	0.10000	0.00781	3.2406
3 1/2	0.4290	3.43	0.2500	2	3.82188	0.4337	3.47	1.6837	1.0000	3.90000	0.10000	0.00781	3.7375
4	0.4560	3.65	0.2500	2	4.31875	0.4337	3.47	1.7337	1.0500	4.40000	0.10000	0.00781	4.2344

¹ Dimensions are in inches.

5. BS21-1973 British Standard Taper Pipe Threads. (Except Dryseal)

$H=0.960237 \times P$
 $h=0.460327 \times P$
 $r=0.137278 \times P$

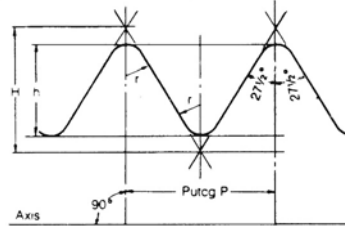

Taper 1 in 16 on dia.
(Shown exaggerated in diagram)

BSP Size (Nominat Bore of Pipe)	No of Threads per inch	Pitch		Depth of Thread		BASIC-Diameters at Grage Plane						Gauge Length							
						Major (Gauge Diameter)		Effective		Minor		Basic		Tolerance Plus and Minus		Max.		Min.	
						in.	mm	in.	mm	in.	mm	in.	mm	in.	mm	in.	mm	in.	mm
1/2	14	0.07143	1.814	0.0457	1.162	0.825	20.955	0.7793	19.793	0.7336	18.631	0.3214	8.2	0.0714	1.8	0.3928	10.0	0.2500	6.4
3/4	14	0.07143	1.814	0.0457	1.162	1.041	24.441	0.9953	25.279	0.9496	24.117	0.3750	9.5	0.0714	1.8	0.4464	11.3	0.3036	7.7
1	11	0.09091	2.309	0.0582	1.479	1.309	33.249	1.2508	31.770	1.1926	30.291	0.4091	10.4	0.0909	2.3	0.5000	12.7	0.3182	8.1
1 1/4	11	0.09091	2.309	0.0582	1.479	1.650	41.910	1.5915	40.431	1.5335	38.952	0.5000	12.7	0.0909	2.3	0.5909	15.0	0.4091	10.4
1 1/2	11	0.09091	2.309	0.0582	1.479	1.882	47.803	1.8238	46.324	1.7656	44.845	0.5000	12.7	0.0909	2.3	0.5909	15.0	0.4091	10.4
2	11	0.09091	2.309	0.0582	1.479	2.347	59.614	2.2888	58.135	2.2306	56.656	0.6250	15.9	0.0909	2.3	0.7159	18.2	0.5341	13.6
2 1/2	11	0.09091	2.309	0.0582	1.479	2.960	75.184	2.9018	73.705	2.8436	72.226	0.6875	17.5	0.1364	3.5	0.8239	21.0	0.5511	14.0
3	11	0.09091	2.309	0.0582	1.479	3.460	87.884	3.4018	86.405	3.3436	84.926	0.8125	20.6	0.1364	3.5	0.9486	24.1	0.6761	17.1
4	11	0.09091	2.309	0.0582	1.479	4.450	113.030	4.3918	111.551	4.3336	110.072	1.0000	25.4	0.1364	3.5	1.1364	28.9	0.8636	21.9
5	11	0.09091	2.309	0.0582	1.479	5.450	138.430	5.3918	136.951	5.3336	135.472	1.1250	28.6	0.1364	3.5	1.2614	32.1	0.9886	25.1
6	11	0.09091	2.309	0.0582	1.479	6.450	162.351	6.3918	162.351	6.3336	160.872	1.1250	28.6	0.1364	3.5	1.2614	32.1	0.9886	25.1

BSP Size (Nominat Bore of Pipe)	No of Threads per inch	Effective Thread, External						Fitting Allowance	Wrenhing Allowance	Tolerance of Position of Gauge Plane Relative to Face of internally Taper Threaded Pairs(Plus and Minuts)		BSP Size (Nominat Bore of Pipe)		
		For Basic Gauge Length		For Max. Gauge Length		For Min. Gauge Length				in.	mm			
		in.	mm	in.	mm	in.	mm			in.	mm			
1/2	14	0.5178	13.2	0.5892	15.0	0.4464	11.4	0.1964	5.0	0.1071	2.7	0.0893	2.3	1/2
3/4	14	0.5714	14.5	0.6428	16.3	0.5000	12.7	0.1964	5.0	0.1071	2.7	0.0893	2.3	3/4
1	11	0.6591	16.8	0.7500	19.1	0.5682	14.5	0.2500	6.4	0.1364	3.5	0.1136	2.9	1
1 1/4	11	0.7500	19.1	0.8509	21.4	0.6591	16.8	0.2500	6.4	0.1364	3.5	0.1136	2.9	1 1/4
1 1/2	11	0.7200	19.1	0.8409	21.4	0.6591	16.8	0.2500	6.4	0.1364	3.5	0.1136	2.9	1 1/2
2	11	0.9204	23.4	1.0113	25.7	0.8259	21.1	0.2954	7.5	0.1818	4.6	0.1364	2.9	2
2 1/2	11	1.0511	26.7	1.1875	30.2	0.9247	23.2	0.3636	9.2	0.2273	5.8	0.1364	3.5	2 1/2
3	11	1.1761	29.8	1.3125	33.3	1.0397	26.3	0.3636	9.2	0.2273	5.8	0.1364	3.5	3
4	11	1.4091	35.8	1.5455	39.3	1.2727	32.3	0.4091	10.4	0.2727	6.9	0.1364	3.5	4
5	11	1.5795	40.1	1.7159	43.6	1.4431	36.6	0.4545	11.5	0.3182	8.1	0.1364	3.5	5
6	11	1.5795	40.1	1.7159	43.6	1.4431	36.6	0.4545	11.5	0.3182	8.1	0.1364	3.5	6

6. Wall Thickness Schedules.

Nominal Pipe Size		Outside Diameter		Nominal Wall Thickness								
A	B	JIS	ANSI	Sch5S	Sch10S	Sch20S	GS	Sch10	LG(7.9)	Sch20	Sch30	STD
8	¼	13.8	13.7	1.2	1.65	2.0	2.3	-	-	-	-	(2.2)
10	⅜	17.3	17.1	1.2	1.65	2.0	2.3	-	-	-	-	(2.3)
15	½	21.7	21.3	1.65	2.1	2.5	2.8	-	-	-	-	(2.8)
20	¾	27.2	26.7	1.65	2.1	2.5	2.8	-	-	-	-	(2.9)
25	1	34.0	33.4	1.65	2.8	3.0	3.2	-	-	-	-	(3.4)
32	1-¼	42.7	42.2	1.65	2.8	3.0	3.5	-	-	-	-	(3.6)
40	1-½	48.6	48.3	1.65	2.8	3.0	3.5	-	-	-	-	(3.7)
50	2	60.5	60.3	1.65	2.8	3.5	3.8	-	-	-	-	(3.9)
65	2-½	76.3	73.0	2.1	3.0	3.5	4.2	-	-	-	-	(5.2)
80	3	89.1	88.9	2.1	3.0	4.0	4.2	-	-	-	-	(5.5)
90	3-½	101.6	101.6	2.1	3.0	4.0	4.2	-	-	-	-	(5.7)
100	4	114.3	114.3	2.1	3.0	4.0	4.5	-	-	-	-	(6.0)
125	5	139.8	141.3	2.8	3.4	5.0	4.5	-	-	-	-	(6.6)
150	6	165.2	168.3	2.8	3.4	5.0	5.0	-	5.0**	-	-	(7.1)
175	7	190.7	-	-	-	-	5.3	-	-	-	-	-
200	8	216.3	219.1	2.8	3.8	6.5	5.8	-	5.8**	6.4	7.0	(8.2)
225	9	241.8	-	-	-	-	6.2	-	-	-	-	-
250	10	267.4	273.1	3.4	4.2	6.5	6.6	-	6.6**	6.4	7.8	(9.3)
300	12	318.5	323.9	4.0	4.6	6.5	6.9	-	6.9**	6.4	8.4	9.5
350	14	355.6	355.6	4.0	4.8	7.9	7.9	6.4	7.9	7.9	9.5	9.5
400	16	406.4	406.4	4.2	4.8	7.9	7.9	6.4	7.9	7.9	9.5	9.5
450	18	457.2	457.2	4.2	4.8	7.9	7.9	6.4	7.9	7.9	11.1	9.5
500	20	508.0	508.0	4.8	5.5	7.9	7.9	6.4	7.9	9.5	12.7	9.5
550	22	558.8	558.8	4.8	5.5	-	-	6.4	7.9	9.5	12.7	9.5
600	24	609.6	609.6	5.5	6.4	-	-	6.4	7.9	9.5	14.3	9.5
650	26	660.4	660.4	-	-	-	-	7.9	7.9	12.7	-	9.5
700	28	711.2	711.2	-	-	-	-	7.9	7.9	12.7	15.9	9.5
750	30	762.0	762.0	6.4	7.9	-	-	7.9	7.9	12.7	15.9	9.5
800	32	812.8	812.8	-	-	-	-	7.9	7.9	12.7	15.9	9.5
850	34	863.6	863.6	-	-	-	-	7.9	7.9	12.7	15.9	9.5
900	36	914.4	914.4	-	-	-	-	7.9	7.9	12.7	15.9	9.5
950	38	965.2	965.2	-	-	-	-	-	7.9	-	-	9.5
1000	40	1016.0	1016.0	-	-	-	-	-	7.9	-	-	9.5
1050	42	1066.8	1066.8	-	-	-	-	-	7.9	-	-	9.5
1100	44	1117.6	1117.6	-	-	-	-	-	7.9	-	-	9.5
1150	46	1168.4	1168.4	-	-	-	-	-	7.9	-	-	9.5
1200	48	1219.2	1219.2	-	-	-	-	-	7.9	-	-	9.5
1250	50	1270.0	1270.0	-	-	-	-	-	*7.9	-	-	*9.5
1300	52	1320.8	1320.8	-	-	-	-	-	*7.9	-	-	*9.5
1350	54	1371.6	1371.6	-	-	-	-	-	*7.9	-	-	*9.5
1400	56	1422.4	1422.4	-	-	-	-	-	*7.9	-	-	*9.5
1450	58	1473.2	1473.2	-	-	-	-	-	*7.9	-	-	*9.5
1500	60	1524.0	1524.0	-	-	-	-	-	*7.9	-	-	*9.5

TECHNICAL DATA

JIS G3448 ANSI B36.10M
 JIS G3454 ANSI B36.19M
 JIS G3455
 JIS G3459

(in mm)

Nominal Wall Thickness									Outside Diameter		Nominal Pipe Size	
Sch40	Sch60	XS	Sch80	Sch100	Sch120	Sch140	Sch160	XXS	JIS	ANSI	A	B
2.2	2.4	(3.0)	3.0	-	-	-	-	-	13.8	13.7	8	¼
2.3	2.8	(3.2)	3.2	-	-	-	-	-	17.3	17.1	10	⅜
2.8	3.2	(3.7)	3.7	-	-	-	4.7	7.5	21.7	21.3	15	½
2.9	3.4	(3.9)	3.9	-	-	-	5.5	7.8	27.2	26.7	20	¾
3.4	3.9	(4.5)	4.5	-	-	-	6.4	9.1	34.0	33.5	25	1
3.6	4.5	(4.9)	4.9	-	-	-	6.4	9.7	42.7	42.2	32	1-¼
3.7	4.5	(5.1)	5.1	-	-	-	7.1	10.2	48.6	48.3	40	1-½
3.9	4.9	(5.5)	5.5	-	-	-	8.7	11.1	60.5	60.3	50	2
5.2	6.0	(7.0)	7.0	-	-	-	9.5	14.0	76.3	73.0	65	2-½
5.5	6.6	(7.6)	7.6	-	-	-	11.1	15.2	89.1	88.9	80	3
5.7	7.0	(8.1)	8.1	-	-	-	12.7	-	101.6	101.6	90	3-½
6.0	7.1	(8.6)	8.6	-	11.1	-	13.5	17.1	114.3	114.3	100	4
6.6	8.1	(9.5)	9.5	-	12.7	-	15.9	19.0	139.8	141.3	125	5
7.1	9.3	(11.0)	11.0	-	14.3	-	18.2	21.9	165.2	168.3	150	6
-	-	-	-	-	-	-	-	-	190.7	-	175	7
8.2	10.3	(12.7)	12.7	15.1	18.2	20.6	23.0	22.2	216.3	219.1	200	8
-	-	-	-	-	-	-	-	-	241.8	-	225	9
9.3	12.7	12.7	15.1	18.3	21.4	25.4	28.6	25.4	267.4	273.1	250	10
10.3	14.3	12.7	17.4	21.4	25.4	28.6	33.3	25.4	318.5	323.9	300	12
11.1	15.1	12.7	19.0	23.8	27.8	31.8	35.7	-	355.6	355.6	350	14
12.7	16.7	12.7	21.4	26.2	30.9	36.5	40.5	-	406.4	406.4	400	16
14.3	19.0	12.7	23.8	29.4	34.9	39.7	45.2	-	457.2	457.2	450	18
15.1	20.6	12.7	26.2	32.5	38.1	44.4	50.0	-	508.0	508.0	500	20
-	22.2	12.7	28.6	34.9	41.3	47.6	54.0	-	558.8	558.8	550	22
17.5	24.6	12.7	31.0	38.9	46.0	52.4	59.5	-	609.6	609.6	600	24
-	-	12.7	-	-	-	-	-	-	660.4	660.4	650	26
-	-	12.7	-	-	-	-	-	-	711.2	711.2	700	28
-	-	12.7	-	-	-	-	-	-	762.0	762.0	750	30
17.5	-	12.7	-	-	-	-	-	-	812.8	812.8	800	32
17.5	-	12.7	-	-	-	-	-	-	863.6	863.6	850	34
19.1	-	12.7	-	-	-	-	-	-	914.4	914.4	900	36
-	-	12.7	-	-	-	-	-	-	965.2	965.2	950	38
-	-	12.7	-	-	-	-	-	-	1016.0	1016.0	1000	40
-	-	12.7	-	-	-	-	-	-	1066.8	1066.8	1050	42
-	-	12.7	-	-	-	-	-	-	1117.6	1117.6	1100	44
-	-	12.7	-	-	-	-	-	-	1168.4	1168.4	1150	46
-	-	12.7	-	-	-	-	-	-	1219.2	1219.2	1200	48
-	-	12.7	-	-	-	-	-	-	1270.0	1270.0	1250	50
-	-	12.7	-	-	-	-	-	-	1320.8	1320.8	1300	52
-	-	12.7	-	-	-	-	-	-	1371.6	1371.6	1350	54
-	-	12.7	-	-	-	-	-	-	1422.4	1422.4	1400	56
-	-	12.7	-	-	-	-	-	-	1473.2	1473.2	1450	58
-	-	12.7	-	-	-	-	-	-	1524.0	1524.0	1500	60

7. Material Specifications

ASTM STANDARD

ASTM	Grade	Classification	Chemical Composition								Mechanical Properties				
			C %	Mn %	P Max. %	S Max. %	Si %	Ni %	Cr %	Mo %	T.S. Min. psi (kg/mm ²)	Y.S. Min. psi (kg/mm ²)	EL Min. %	Red. Min. %	HB
A-105*		Carbon Steel	MAX 0.35	0.60~1.05	0.040	0.050	MAX 0.35	MAX 0.40	MAX 0.30	MAX 0.12	70,000 (49.2)	36,000 (25.3)	22	30	MAX 187
A-181* 60		Carbon Steel	MAX 0.35	MAX 0.90	0.050	0.050	MAX (0.35)				60,000 (42.2)	30,000 (21.1)	22	35	
A-181 70		Carbon Steel	MAX 0.35	MAX 0.90	0.050	0.050	MAX (0.35)				70,000 (49.2)	36,000 (25.3)	18	24	
A-182 F1		½ Mo	MAX 0.28	0.60~0.90	0.045	0.045	0.15~0.35			0.44~0.65	70,000 (49.2)	40,000 (28.1)	20	30	143~192
A-182 F5		5Cr-½ Mo	MAX 0.15	0.30~0.60	0.030	0.030	MAX 0.50	MAX 0.50	4.00~6.00	0.44~0.65	70,000 (49.2)	40,000 (28.1)	20	35	143~217
A-182 F5a		5Cr-½ Mo	MAX 0.25	MAX 0.60	0.040	0.030	MAX 0.50	MAX 0.50	4.00~6.00	0.44~0.65	90,000 (63.3)	65,000 (45.7)	22	50	187~248
A-182 F11-1		1¼Cr-½ Mo	0.05~0.15	0.30~0.60	0.030	0.030	0.50~1.00		1.00~1.50	0.44~0.65	60,000 (42.2)	30,000 (21.1)	20	45	121~174
A-182 F11-2		1¼Cr-½ Mo	0.10~0.20	0.30~0.80	0.040	0.040	0.50~1.00		1.00~1.50	0.44~0.65	70,000 (49.2)	40,000 (28.1)	20	30	143~207
A-182 F11-3		1¼Cr-½ Mo	0.10~0.20	0.30~0.80	0.040	0.040	0.50~1.00		1.00~1.50	0.44~0.65	75,000 (52.7)	45,000 (31.6)	20	30	156~207
A-182 F12-1		1Cr-½ Mo	0.05~0.15	0.30~0.60	0.045	0.045	MAX 0.50		0.80~1.25	0.44~0.65	60,000 (42.2)	30,000 (21.1)	20	45	121~174
A-182 F12-2		1Cr-½ Mo	0.10~0.20	0.30~0.80	0.040	0.040	0.10~0.60		0.80~1.25	0.44~0.65	70,000 (49.2)	40,000 (28.1)	20	30	143~174
A-182 F11		1¼Cr-½ Mo	0.10~0.20	0.30~0.60	0.040	0.040	0.50~1.00		1.00~1.50	0.44~0.65	70,000 (49.2)	40,000 (28.1)	20	30	143~207
A-182 F12		1Cr-½ Mo	0.10~0.20	0.30~0.80	0.040	0.040	0.10~0.60		0.80~1.25	0.44~0.65	70,000 (49.2)	40,000 (28.1)	20	30	143~207
A-182 F22		2¼Cr-1 Mo	MAX 0.15	0.30~0.60	0.040	0.040	MAX 0.50		2.00~2.50	0.87~1.13	75,000 (52.7)	45,000 (31.6)	20	30	156~207
A-182 F304		18Cr-8 Ni	MAX 0.08	MAX 2.00	0.040	0.030	MAX 1.00	8.00~11.00	18.00~20.00		75,000 (52.7)	30,000 (21.1)	30	50	
A-182 F304L		18Cr-8 Low Ni	MAX 0.035	MAX 2.00	0.040	0.030	MAX 1.00	8.00~13.00	18.00~20.00		75,000 (49.2)	25,000 (17.6)	30	50	
A-182 F316		18Cr-8 Mo Ni	MAX 0.08	MAX 2.00	0.040	0.030	MAX 1.00	10.00~14.00	16.00~18.00	2.00~3.00	75,000 (52.7)	30,000 (21.7)	30	50	
A-182 F316L		18Cr-8 Mo-Low Ni	MAX 0.035	MAX 2.00	0.040	0.030	MAX 1.00	10.00~15.00	16.00~18.00	2.00~3.00	65,000 (45.7)	25,000 (17.6)	30	50	
A-182 F321		18Cr-8 Ti Ni	MAX 0.08	MAX 2.00	0.030	0.030	MAX 1.00	9.00~12.00	Min 17.00		75,000 (52.7)	30,000 (21.1)	30	50	
A-182 F347		18Cr-8 Cb Ni	MAX 0.08	MAX 2.00	0.030	0.030	MAX 1.00	9.00~13.00	17.00~20.00		75,000 (52.7)	30,000 (21.1)	30	50	
A-350* LF1		Carbon Steel	MAX 0.30	0.75~1.05	0.035	0.040	0.15~0.30	MAX 0.40	MAX 0.30	MAX 0.12	60,000~85,000 (42.2~59.7)	30,000 (21.1)	25	38	
A-350* LF2		Carbon Steel	MAX 0.30	MAX 1.35	0.035	0.040	0.15~0.30	MAX 0.40	MAX 0.30	MAX 0.12	70,000~95,000 (49.2~66.8)	36,000 (25.3)	22	30	
A-350* LF3		3½ Ni	MAX 0.20	MAX 0.90	0.035	0.040	0.20~0.35	3.25~3.75	MAX 0.30	MAX 0.12	70,000~95,000 (49.2~66.8)	37,500 (26.4)	22	35	

- OTHER ELEMENTS : copper (0.40% MAX.), Vanadium, (0.03% MAX.), Columbium (0.02% MAX.)
- The sum of Cu, Ni, Cr and Mo Shall not be exceed 1.00%
- The sum of Cr and Mo shall not be exceed 0.32%

Leak - Proof Flow & Control Solution Partner

Hansun

한선엔지니어링(주)
HANSUN ENGINEERING CO., LTD.

27 Noksansandan361-ro, Gangseo-gu
(Songjeong-dong), Busan, Korea

Tel : +82-51-899-6700, Fax : +82-51-899-6799

E-Mail : overseas@ehansun.co.kr

sales@ehansun.co.kr

Website : www.ehansun.co.kr, www.slok.co.kr