



Bourdon Tube Pressure Gauges

High Purity Cleaned Gauges

Stainless Steel Wetted Parts

Type 130.15

Application

Fluid mediums for semiconductor, Clean Dry Air (CDA), and other high purity applications that require both high purity cleaning and a high degree of accuracy. Fluid medium which does not corrode 316 stainless steel. Any medium which oxidizes with oil based materials.

Sizes

2" (50 mm)

Accuracy

± 2/1/2% of span (ASME B40.1 Grade A)

Ranges (All ranges not stocked)

Vacuum / Compound to 30"HG / 0 / 300 PSI

Pressure from 15 PSI to 10,000 PSI or other equivalent units of pressure or vacuum

Working Range

Steady: 3/4 of full scale value

Fluctuating: 2/3 of full scale value

Short time: full scale value

Operating Temperature

Ambient: -40°F to 140°F (-40°C to 60°C)

Media: max. 140°F (+60°C)

Temperature Error

Additional error when temperature changes from reference temperature of 68°F (20°C) ±0.4% for every 18°F (10°C) rising or falling. Percentage of span.

Standard Features

Connection

Material: 316 stainless steel

Lower mount (LM)

Center back mount (CBM)

1/8" or 1/4" NPT limited to wrench flat area

Bourdon Tube

Material: 316 stainless steel

15 PSI to 1,000 PSI C-type

1,500 PSI to 10,000 PSI helical type

Helium leak tested 2×10^{-9} (Inboard)

Movement

Stainless steel

Dial

White aluminum with stop pin and black lettering

Pointer

Black aluminum

Case

Electropolished stainless steel

Window

Twist-lock polycarbonate



Cleanliness

ASME B40.1 Level IV (for oxygen service)

Cleaned and packaged in a Class 100 cleanroom

Packaged in single nylon bag

Purged with Nitrogen

Protective cap over thread connection

Order Options (min. order may apply)

Alarm contact (830.1E)

Monel wetted parts

Hastelloy wetted parts

Packaged in two nylon bags

Other special connections limited to wrench flat area

Custom dial layout

Stainless steel restrictor

Particle test with certificate

Dual scales

APM 130.15
(APM 01.05.2)

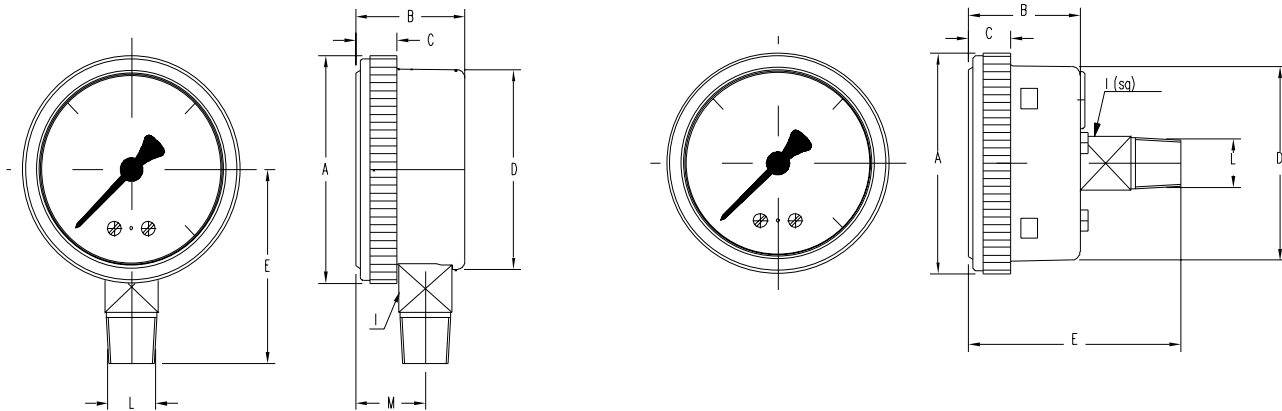

TYPE	WEIGHT	KEY	A	B	C	D	E	I	L	M
130.15 2" LM	0.25 lbs.	mm	57.8	29	11	50.7	49.3	14	---	18.5
		in	2.28	1.14	0.43	2.0	1.94	0.55	1/4" NPT	0.73
130.15 2" CBM	0.31 lbs.	mm	57.8	29	11	50.7	55.1	14	---	---
		in	2.28	1.14	0.43	2.0	2.17	0.55	1/4" NPT	---

THE MEASURE OF
Total Performance™

Ordering Information:

State computer part number (if available) / type number / size / range / connection size and location / options required.

Specifications given in this price list represent the state of engineering at the time of printing. Modifications may take place and the specified materials may change without prior notice.

11/2003



WIKAI Instrument Corporation

1000 Wiegand Boulevard

Lawrenceville, Georgia 30043-5868

Tel: 770-513-8200 Fax: 770-338-5118

http://www.wika.com e-mail: uhpinfo@wika.com