

## Spiral Duct

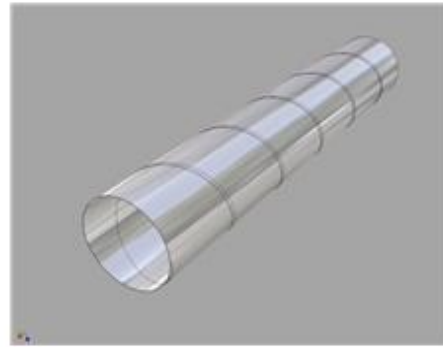

Serial No.	Specification			Remark
	A Diameter (mm)	L Length (M)	T Thickness (mm)	
SD-100A	100A	4	0.5	
SD-125A	125A	4	0.5	
SD-150A	150A	4	0.5	
SD-200A	200A	4	0.5	
SD-250A	250A	4	0.5	
SD-300A	300A	4	0.5	

## Spiral Elbow 90°

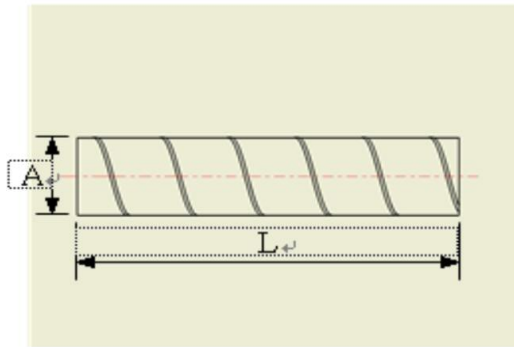
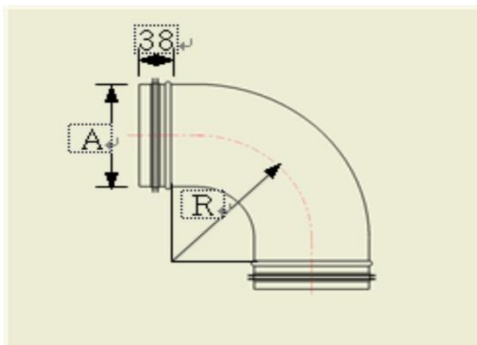

Serial No.	Specification			Remark
	A Diameter (mm)	R Radius (mm)	T Thickness (mm)	
SE-100A-90	100A	104	0.5	
SE-125A-90	125A	129	0.5	
SE-150A-90	150A	154	0.5	
SE-200A-90	200A	204	0.5	
SE-250A-90	250A	254	0.5	
SE-300A-90	300A	304	0.5	

## Spiral Elbow 45°

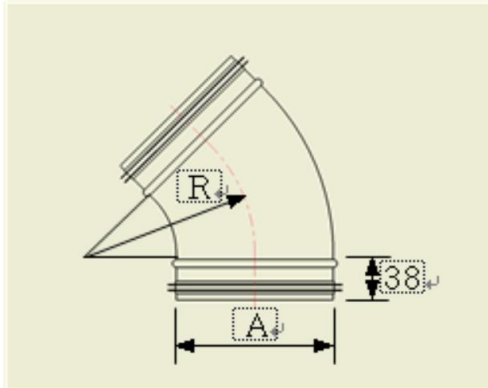

Serial No.	Specification			Remark
	A Diameter (mm)	R Radius (mm)	T Thickness (mm)	
SE-100A-45	100A	104	0.5	
SE-125A-45	125A	129	0.5	
SE-150A-45	150A	154	0.5	
SE-200A-45	200A	204	0.5	
SE-250A-45	250A	254	0.5	
SE-300A-45	300A	304	0.5	

## Spiral Elbow 30°

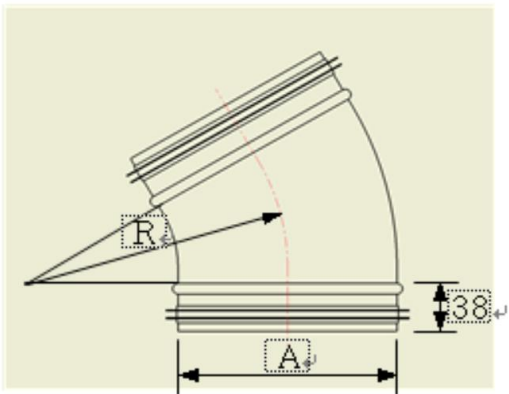

Serial No.	Specification			Remark
	A Diameter (mm)	R Radius (mm)	T Thickness (mm)	
SE-100A-30	100A	104	0.5	
SE-125A-30	125A	129	0.5	
SE-150A-30	150A	154	0.5	
SE-200A-30	200A	204	0.5	
SE-250A-30	250A	254	0.5	
SE-300A-30	300A	304	0.5	

## Spiral Tee

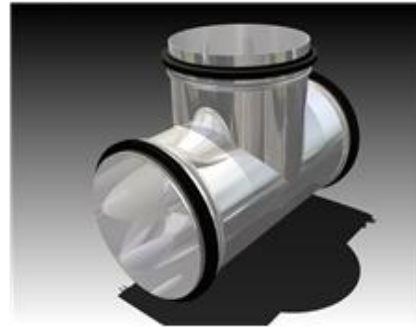
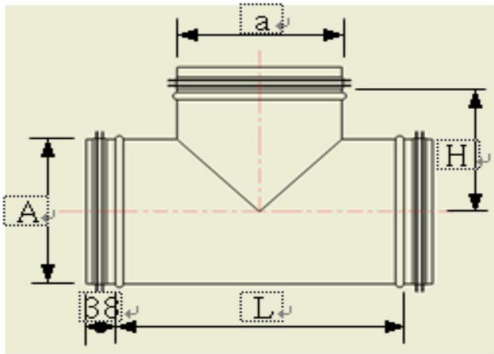

Serial No.	Specification				Remark
	A, a Diameter (mm)	L Length (mm)	H Height (mm)	T Thickness (mm)	
ST-100A	100A	165	80	0.5	
ST-125A	125A	200	90	0.5	
ST-150A	150A	250	109	0.5	
ST-200A	200A	300	140	0.5	
ST-250A	250A	370	190	0.5	
ST-300A	300A	450	195	0.5	

## Spiral Reducer

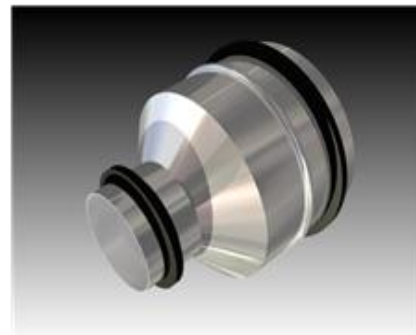
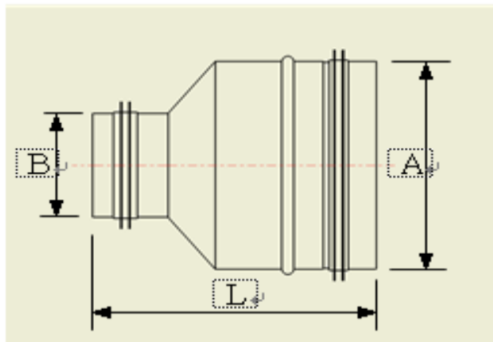

Serial No.	Specification				Remark
	A Diameter (mm)	B Diameter (mm)	L Length (mm)	T Thickness (mm)	
SR-100	100A	50A	118	0.5	
SR-125	125A	100A	118	0.5	
SR-150	150A	125A	118	0.5	
SR-200	200A	150A	118	0.5	
SR-250	250A	200A	118	0.5	
SR-300	300A	250A	118	0.5	

## Spiral Coupling

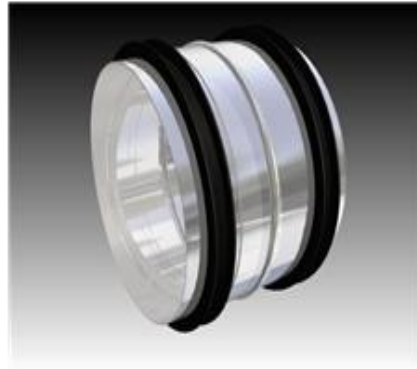
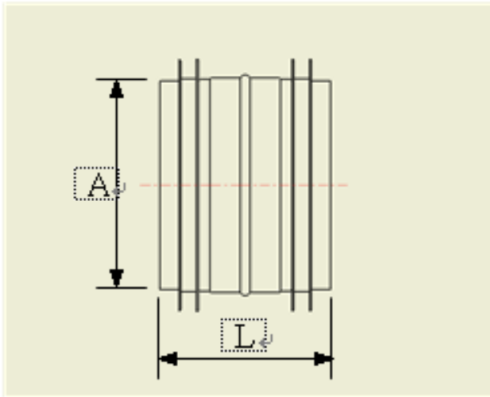

Serial No.	Specification			Remark
	A Diameter (mm)	L Length (mm)	T Thickness (mm)	
SC-100A	100A	82	0.5	
SC-125A	125A	82	0.5	
SC-150A	150A	82	0.5	
SC-200A	200A	82	0.5	
SC-250A	250A	82	0.5	
SC-300A	300A	82	0.5	

## Spiral Damper (Duct용)

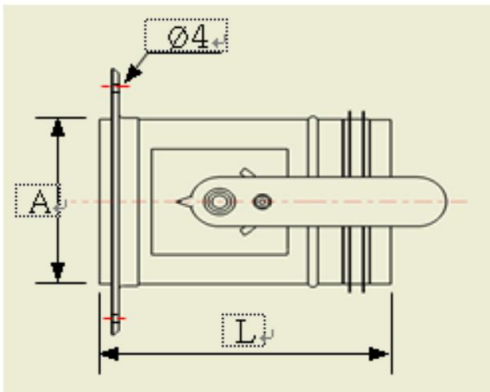

Serial No.	Specification				Remark
	A Diameter (mm)	L Length (mm)	T Thickness (mm)	H Hole No. (EA)	
SVD-100A-D	100A	160	0.5	6	
SVD-125A-D	125A	170	0.5	6	
SVD-150A-D	150A	190	0.5	6	
SVD-200A-D	200A	210	0.5	6	
SVD-250A-D	250A	280	0.5	6	

SVD-300A-D	300A	320	0.5	6	
------------	------	-----	-----	---	--

## Spiral Damper (Ceiling용)

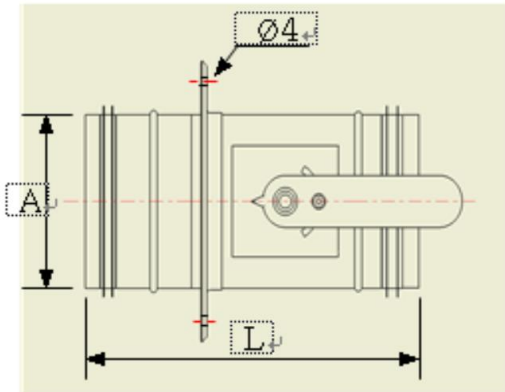

Serial No.	Specification				Remark
	A Diameter (mm)	L Length (mm)	T Thickness (mm)	H Hole No. (EA)	
SVD-100A-C	100A	210	0.5	6	
SVD-125A-C	125A	230	0.5	6	
SVD-150A-C	150A	245	0.5	6	
SVD-200A-C	200A	280	0.5	6	
SVD-250A-C	250A	335	0.5	6	
SVD-300A-C	300A	380	0.5	6	

## Spiral Take Off

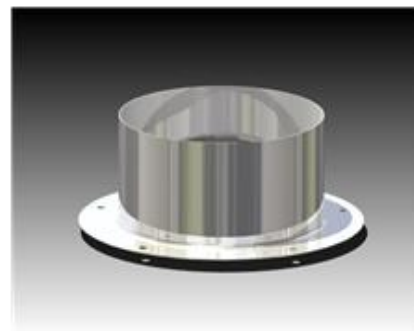
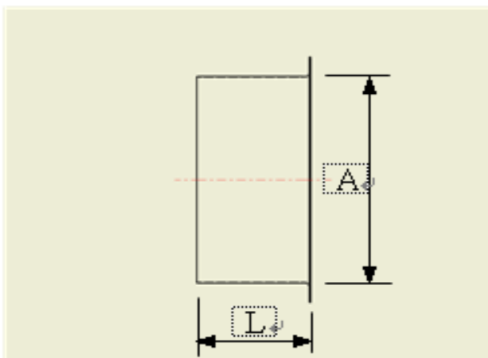

Serial No.	Specification			Remark
	A Diameter (mm)	L Length (mm)	T Thickness (mm)	
STO-100A	100A	50	0.5	
STO-125A	125A	50	0.5	
STO-150A	150A	50	0.5	
STO-200A	200A	50	0.5	
STO-250A	250A	50	0.5	

STO-300A	300A	50	0.5	
----------	------	----	-----	--

## Spiral Sleeve

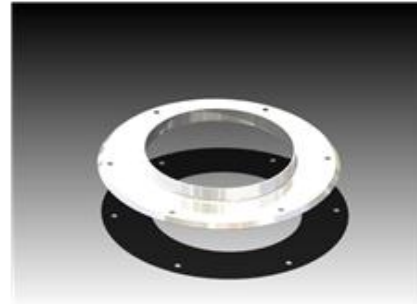
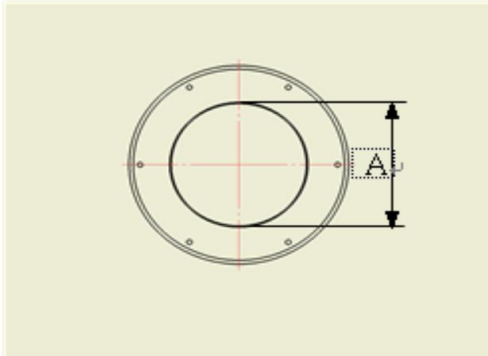

Serial No.	Specification				Remark
	A Diameter (mm)	L Length (mm)	T Thickness (mm)	H Hole No. (EA)	
SS-100A	100A	15	0.5	6	
SS-125A	125A	15	0.5	6	
SS-150A	150A	15	0.5	6	
SS-200A	200A	15	0.5	6	
SS-250A	250A	15	0.5	6	
SS-300A	300A	15	0.5	6	

## Spiral Cap

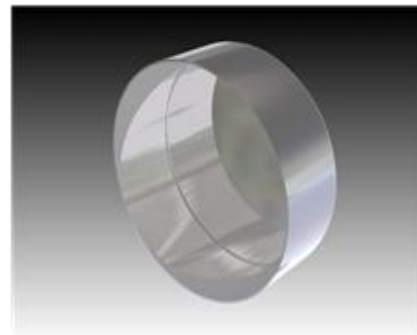
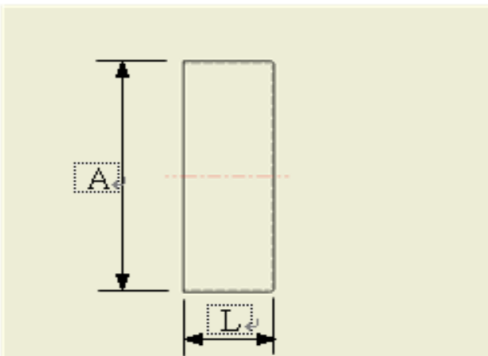

Serial No.	Specification			Remark
	A Diameter (mm)	L Length (mm)	T Thickness (mm)	
SCA-100A	100A	50	0.5	
SCA-125A	125A	50	0.5	
SCA-150A	150A	50	0.5	
SCA-200A	200A	50	0.5	
SCA-250A	250A	50	0.5	
SCA-300A	300A	50	0.5	

